

ZES Sensors and Accessories

**for precision power meters
LMG series 90/310/95/450/500**

Contains Discontinued Products

ZES current and voltage sensors and accessories

This data book is the technical documentation of the current and voltage sensors from ZES ZIMMER Electronic Systems GmbH to enlarge the measuring ranges of the power meters series LMG.

The first section of this paper gives an survey of all ZES current sensors and the safety precautions. Selection table and several arguments should help you to find a suitable sensor family or fill out the support request form. The second section is about the general current sensors, which you can use with every precision power meter of the LMG series. In the following sections the special sensors, wiring cables and accessories for the different precision power meters are described. Then you find a chapter with the precision high voltage divider for meters of the LMG series. The last section with frequently asked questions will help you to optimize the accuracy and give you some hints for the usage of our sensors.

But in all cases if you need more information or detailed support for your application please don't hesitate to contact us, the engineers of ZES ZIMMER will help you.

© Copyright 2020. No part of this document may be reproduced, in any form or by any means, without the permission in writing from ZES ZIMMER Electronic Systems GmbH.

We reserve the right to implement technical changes at any time, particularly where these changes will improve the performance.

- Headquarter Germany:
ZES ZIMMER Electronic Systems GmbH
Tabaksmühlenweg 30
D-61440 Oberursel (Taunus), Germany
phone ++49 (0)6171 628750
fax ++49 (0)6171 52086
email: sales@zes.com
internet: <http://www.zes.com>
- Subsidiary USA:
ZES ZIMMER Inc.
2850 Thornhills Ave. SE
Suite 114
Grand Rapids, MI 49546, USA
phone +1 760 550 9371
email: usa@zes.com
internet: <http://www.zes.com>

Content

1 Introduction.....	4
1.1 Safety precautions	4
2 Current sensors	7
2.1 Active error compensated AC - current clamp 40A (LMG-Z406/-Z407) .	7
2.2 AC - current clamp 200A/0.2A (LMG-Z326)	10
2.3 AC - current clamp 200A/1A (LMG-Z325)	12
2.4 Error compensated AC - current clamp 1000A (L45-Z10/-Z11)	14
2.5 DC - current clamp 1000A (L45-Z26).....	17
2.6 Error compensated AC - current clamp 3000A (L45-Z16/-Z17)	19
2.7 Hall current sensors, 50/100/200A (L45-Z28-HALLxx)	22
2.8 Hall current sensors, 300/500/1k/2kA (L45-Z29-HALLxx).....	25
2.9 Hall current sensors, 300/500/1k/2kA (L50-Z29-HALLxx).....	29
2.10 Rogowski flex sensors (L45-Z32-FLEXxx).....	32
3 LMG95 connection cables and adapter	35
3.1 Adapter for the use of HD15-Sensors with LMG95 (L95-Z07)	35
3.2 PSU/PCT-K-L95	36
4 LMG450 connection cables and adapter	39
4.1 BNC adapter to sensor input HD15 without EEPROM (L45-Z09)	39
4.2 Adapter for isolated custom current sensors with 1A output (L45-Z22). 40	
5 LMG500 connection cables and adapter	43
5.1 LMG500 current sensor adapter (L50-Z14)	43
6 Accessories	45
6.1 Sensor supply unit for up to 4 current sensors (SSU4)	45
6.2 Adapter for incremental rotation speed encoders (L45-Z18).....	51
6.3 Adapter for incremental rotation speed encoders (L50-Z18).....	55
6.4 Synchronisation adapter with adjustable lowpass filter (L50-Z19)	59
6.5 Ethernet Adapter (L95-Z318, L45-Z318, L50-Z318, LMG-Z318).....	61
7 FAQ - frequently asked questions / Knowledge base	67
7.1 Example of an error calculation: general derivation	67
7.2 Example of an error calculation: LMG95 with external shunt.....	71
7.3 Example of an error calculation: LMG500 with HST3	72

1 Introduction

1.1 Safety precautions







The following precautions are recommended to insure your safety and to provide the best conditions for the instruments.

- When using voltage or current transformers please regard the applicable safety standards (earthing, isolation, ...)!
- The installation of powermeter and current sensors may be accomplished only by trained technical personnel!
- When operating the powermeter, current- and voltage sensors, certain parts can carry hazardous voltage (e.g. primary busbar, power supply). Ignoring this warning can lead to injury and/or cause serious damage.
- Read the user manual carefully and respect the safety precautions!
- Do not use these products in medical-related or any other equipment that may have a potential effect on human lives.
- Always observe the operating conditions and environmental requirements as indicated in this documentation when operating the product.
- Do not exceed the maximum specified voltage or current or use outside its measurement category.
- Always check the condition of the case and leads before use. Never operate the unit if it has a damaged cord or plug, if it is not working properly, or if it has been dropped or damaged or dropped into water.
- Avoid severe impacts or rough handling that could damage the instrument. Do not place any heavy object on the instrument.
- Keep the instruments away from water and other liquids.
- Use electrostatic discharge precautions while handling and making connections to the instrument.
- Do not block or obstruct the ventilation openings.

- Use suitable connection cables. Different current sensors have unique connection cables for each different precision power meter LMG. For example: the connection cable between PSU200 and LMG500 'PSU200-K-L50' is neither suitable for PSU600 nor for LMG450.
- To avoid the risk of electrical shock, do not disassemble or attempt to repair the unit. Incorrect repair can cause risk of electrical shock or injury to persons when unit is used. For all repairs please return the devices to your distributor or to ZES ZIMMER Electronic Systems.
- Do not touch energized circuits.
- The power meter with its voltage and current sensors is not designed to detect hazards or similar! A wrong reading (e.g. by choosing a wrong filter or range) could give you the wrong impression of a safe state. Use appropriate tools instead of this instrument to detect dangerous situations.

1.1.1 Terms and symbols

These terms and symbols may appear in this manual or on the product.

	Warning, risk of danger! Refer to the operating instructions before using the device. In these operating instructions, failure to follow or carry out instructions preceded by this symbol may result in personal injury or damage to the device.
	Caution, risk of electric shock
	Earth (ground) terminal
	Protective conductor terminal
	Equipment protected throughout by double insulation or reinforced insulation.
	Application around and removal from hazardous live conductors is permitted.
	Do not apply around or remove from hazardous live conductors.

	<p>This symbol indicates that this product is to be collected separately. This product is designated for separate collection at an appropriate collection point. Do not dispose of as household waste. For more information, contact the retailer or the local authorities in charge of waste management.</p>
---	---

1.1.2 Definition of measurement categories

- Measurement category IV corresponds to measurements taken at the source of low voltage installations.
- Measurement category III corresponds to measurements on building installations.
- Measurement category II corresponds to measurements taken on circuits directly connected to low voltage installations.
- Measurement category I corresponds to measurements taken on circuits not directly connected to mains.

2 Current sensors

2.1 Active error compensated AC - current clamp 40A (LMG-Z406/-Z407)

(LMG-Z407 is a set of 4x LMG-Z406)

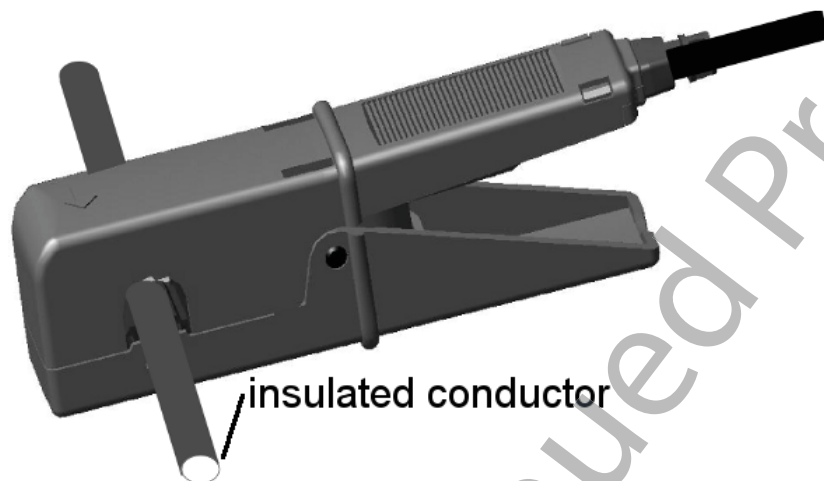

Figure 1: LMG-Z406/-Z407

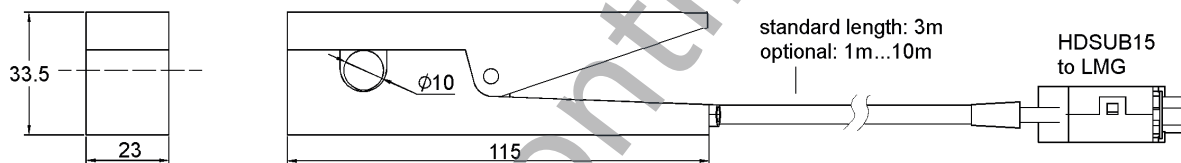

Figure 2: Dimensions of the LMG-Z406/-Z407

2.1.1 Safety warning!

No safety isolation, measurements only at insulated conductors allowed!

Always connect the sensor first to the meter, and afterwards to the device under test.

Connecting cable without safety isolation! Avoid contact to hazardous voltage!

Please refer to chapter 1.1: 'Safety precautions'!

2.1.2 Specifications

Nominal input current	40A
Max. trms value	80A
Measuring range current clamp	120A _{pk}
Maximum input, overload capability	500A for 1s
Bandwidth	5Hz to 50kHz

Isolation	bare conductor: phase/ground 30Veff insulated conductor: see cable spec.
Degree of pollution	2
Temperature range	-10°C to +50°C
Weight	120g
Output connection	HD15 (with EEPROM) for LMG sensor input

With its high basic accuracy, the lower cut-off frequency of 5Hz and the upper cut-off frequency of 50kHz this clamp fits best for measurements at frequency inverter output. The internal error compensation circuit is designed especial for this application.

2.1.3 Accuracy

Accuracies based on: sinusoidal current, ambient temperature $23\pm 3^{\circ}\text{C}$, calibration interval 1 year, conductor in the middle of the clamp. The values are in $\pm(\%$ of measuring value + $\%$ of measuring range current clamp) and in $\pm(\text{phase error in degree})$

Influence of coupling mode: This current clamp can transfer only AC currents. The compensation circuit may cause a DC signal which is interpreted by the instrument as a DC current. This could cause additional errors. Therefore this clamp should only be used with the LMG setting: AC coupling. The accuracies are only valid for this case.

Frequency	5Hz to 10Hz	10Hz to 45Hz	45Hz to 65Hz	65Hz to 1kHz	1kHz to 5kHz	5kHz to 20kHz	20kHz to 50kHz
Current	1.5+0.25	0.4+0.15	0.15+0.05	0.15+0.05	0.3+0.15	1+0.25	4+0.5
Phase	6	3	0.5	0.5	2	6	20

Use LMG-Z406/-Z407 and LMG specifications to calculate the accuracy of the complete system.

2.1.4 Ordering guide

The current clamp LMG-Z406 is available in a package with 4 clamps, it is called LMG-Z407.

The standard connection length is 3m. Optionally can be ordered a custom defined length between 1m .. 10m.

2.1.5 Sensor operation without supply

It is important to assure a stable power supply of the sensor before switching on the load current! The **operation** of the sensor with load current and **without supply will cause damage** of the sensor and/or of the LMG.

2.1.6 Connection of the sensor with LMG90/310

The use with LMG90 and LMG310 is not possible.

2.1.7 Connection of the sensor with LMG95

Use L95-Z07, internal supply via LMG and the Isensor/external shunt input. Set LMG current scaling factor appropriate to the scaling factor marked on the label on L95-Z07.

2.1.8 Connection of the sensor with LMG450

Use the sensor input, you get the following ranges:

nominal value	1.25A	2.5A	5A	10A	20A	40A
max. trms value	2.5A	5A	10A	20A	40A	80A
max. peak value	3.75A	7.5A	15A	30A	60A	120A

2.1.9 Connection of the sensor with LMG500

Use L50-Z14, you get the following ranges:

nominal value	0.3A	0.6A	1.25A	2.5A	5A	10A	20A	40A
max. trms value	0.6A	1.25A	2.5A	5A	10A	20A	40A	80A
max. peak value	0.94A	1.88A	3.75A	7.5A	15A	30A	60A	120A

2.2 AC - current clamp 200A/0.2A (LMG-Z326)

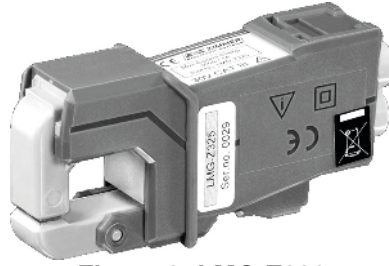

Figure 3: LMG-Z326

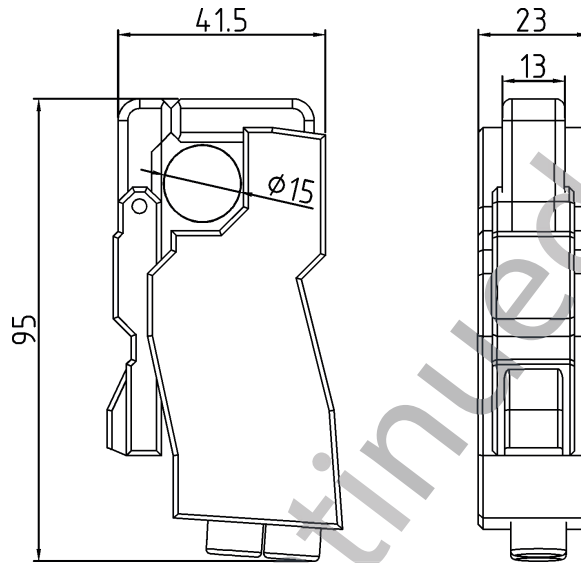

Figure 4: Dimensions of the LMG-Z326

2.2.1 Safety warning!

No safety isolation, measurements only at insulated conductors allowed!

Always connect the sensor first to the meter, and afterwards to the device under test.

Please refer to chapter 1.1: 'Safety precautions'!

2.2.2 Specifications

Nominal input current	200A
Transformation ratio	1000:1
Measuring range	600A
Maximum input	600A for 3min
Bandwidth	40Hz to 10kHz
Burden	1 to 10 ohms
Isolation	bare conductor: phase/ground 30Veff insulated conductor: see cable spec.

Degree of pollution	2
Temperature range	-10°C to +50°C
Weight	105g
Output connection	2 safety sockets for 4mm plugs

2.2.3 Accuracy

Accuracies based on: sinusoidal current, ambient temperature 23±3°C, calibration interval 1 year, conductor in the middle of the clamp, signal frequency 50..60 Hz.

Current	Amplitude error ±(% of measuring value)	Phase error
1A to 10A	3	not specified
10A to 25A	2	2°
25A to 600A	1	1°

Use LMG-Z326 and LMG specifications to calculate the accuracy of the complete system.

2.2.4 Sensor operation without connection to LMG

It is important to assure a good connection from the sensor to the LMG before switching on the load current! The **operation** of the sensor with load current and **without connection to the LMG will cause damage** of the sensor and is **dangerous** for the user!

2.2.5 Connection of the sensor with LMG90/310 or other instruments with current input

Use direct current inputs I* and I.

2.2.6 Connection of the sensor with LMG95

Use direct current inputs I* and I.

2.2.7 Connection of the sensor with LMG450

Use direct current inputs I* and I.

2.2.8 Connection of the sensor with LMG500

Use direct current inputs I* and I.

2.3 AC - current clamp 200A/1A (LMG-Z325)

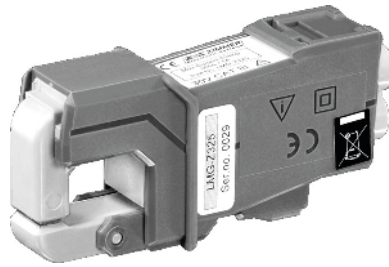

Figure 5: LMG-Z325

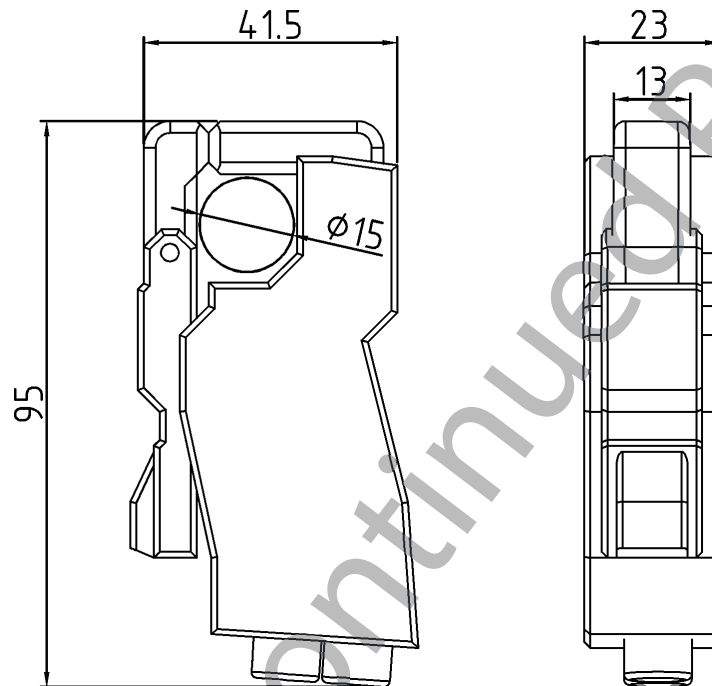

Figure 6: Dimensions of the LMG-Z325

2.3.1



Safety warning!

No safety isolation, measurements only at insulated conductors allowed!

Always connect the sensor first to the meter, and afterwards to the device under test.

Please refer to chapter 1.1: 'Safety precautions'!

2.3.2 Specifications

Nominal input current	200A
Transformation ratio	200:1
Measuring range	250A
Maximum input	250A for 3min
Bandwidth	40Hz to 5kHz

Burden	1 to 2 ohms
Isolation	bare conductor: phase/ground 30Veff insulated conductor: see cable spec.
Degree of pollution	2
Temperature range	-10°C to +50°C
Weight	115g
Output connection	safety sockets for 4mm plugs

2.3.3 Accuracy

Accuracies based on: sinusoidal current, ambient temperature $23\pm 3^{\circ}\text{C}$, conductor in the middle of the clamp, signal frequency 50..60 Hz.

Current	Amplitude error \pm (% of measuring value)	Phase error
5A to 10A	3	not specified
10A to 25A	2	2.5°
25A to 250A	1	1°

Use LMG-Z325 and LMG specifications to calculate the accuracy of the complete system.

2.3.4 Sensor operation without connection to LMG

It is important to assure a good connection from the sensor to the LMG before switching on the load current! The **operation** of the sensor with load current and **without connection to the LMG will cause damage** of the sensor and is **dangerous** for the user!

2.3.5 Connection of the sensor with LMG90/310 or other instruments with current input

Use direct current inputs I* and I.

2.3.6 Connection of the sensor with LMG95

Use direct current inputs I* and I.

2.3.7 Connection of the sensor with LMG450

Use direct current inputs I* and I.

2.3.8 Connection of the sensor with LMG500

Use direct current inputs I* and I.

2.4 Error compensated AC - current clamp 1000A (L45-Z10/-Z11)

(L45-Z11 is a set of 4x L45-Z10)



Figure 7: L45-Z10/-Z11

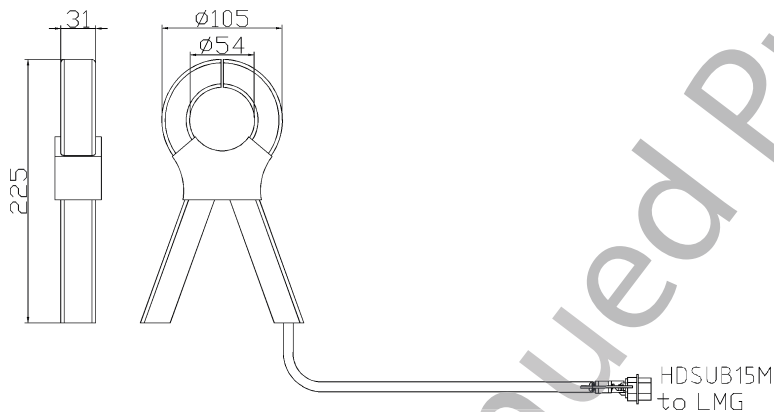

Figure 8: Dimensions of the L45-Z10/-Z11

2.4.1



Safety warning!

Always connect the sensor first to the meter, and afterwards to the device under test.
Connecting cable without safety isolation! Avoid contact to hazardous voltage!
Please refer to chapter 1.1: 'Safety precautions'!

2.4.2 Specifications

Nominal input current	1000A
Max. trms value	1200A
Measuring range current clamp	3000A _{pk}
Maximum input	1200A for 30min
Bandwidth	2Hz to 40kHz
Protection class	600V CAT. III
Degree of pollution	2
Temperature range	-10°C to +50°C
Weight	650g
Output connection	HD15 (with EEPROM) for LMG sensor input,

connection length 1.7 m

2.4.3 Accuracy

Accuracies based on: sinusoidal current, ambient temperature $23\pm 3^{\circ}\text{C}$, calibration interval 1 year, conductor in the middle of the clamp.

The values are in \pm (% of measuring value + % of measuring range current clamp) and in \pm (phase error in degree)

Frequency	2Hz to 10Hz	10Hz to 45Hz	45Hz to 65Hz	65Hz to 1kHz	1kHz to 5kHz	5kHz to 10kHz	10kHz to 20kHz	20kHz to 40kHz
Current	0.7+0.2	0.2+0.05	0.1+0.05	0.1+0.05	0.3+0.05	0.4+0.1	0.5+0.2	2+0.4
Phase	5	1	0.3	0.3	1	2	5	30

Use L45-Z10 and LMG specifications to calculate the accuracy of the complete system.

Influence of coupling mode: This current clamp can transfer only AC currents. The compensation circuit may cause a DC signal which is interpreted by the instrument as a DC current. This could cause additional errors. Therefore this clamp should only be used with the LMG setting: AC coupling. The accuracies are only valid for this case.

2.4.4 Connection of the sensor with LMG90/310

The use with LMG90 and LMG310 is not possible.

2.4.5 Connection of the sensor with LMG95

Use L95-Z07, internal supply via LMG and the Isensor/external shunt input. Set LMG current scaling factor appropriate to the scaling factor marked on the label on L95-Z07.

2.4.6 Connection of the sensor with LMG450

Use sensor input, you get the following ranges:

nominal value	31.2A	62.5A	125A	250A	500A	1000A
max. trms value	37.5A	75A	150A	300A	600A	1200A
max. peak value	93.8A	188A	375A	750A	1500A	3000A

2.4.7 Connection of the sensor with LMG500

Use L50-Z14, you get the following ranges:

nominal value	7.5A	15A	30A	62.5A	125A	250A	500A	1000A
max. trms value	9.4A	18.8A	37.5A	75A	150A	300A	600A	1200A

max. peak value	23.4A	46.9A	93.8A	188A	375A	750A	1500A	3000A
-----------------	-------	-------	-------	------	------	------	-------	-------

Contains Discontinued Products

2.5 DC - current clamp 1000A (L45-Z26)



Figure 9: L45-Z26

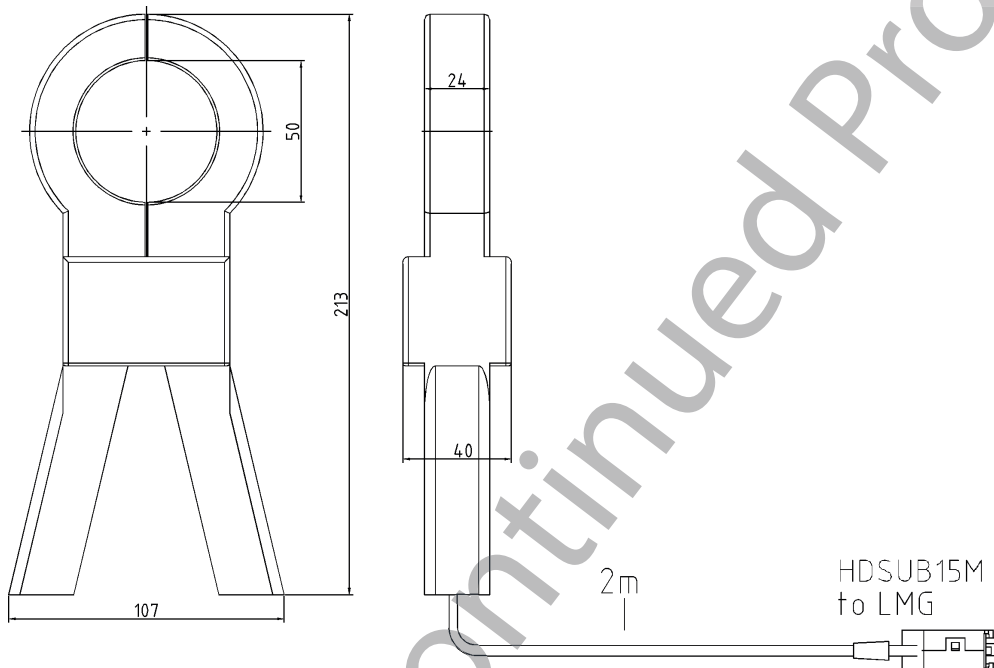

Figure 10: Dimensions of the L45-Z26

2.5.1



Safety warning!

Always connect the sensor first to the meter, and afterwards to the device under test. Connecting cable without safety isolation! Avoid contact to hazardous voltage! Please refer to chapter 1.1: 'Safety precautions'!

2.5.2 Specifications

Nominal input current	1000A
Max. trms value	1000A
Measuring range	1500A _{pk}
Maximum input	1500A
Bandwidth	DC to 2kHz
Protection class	600V CAT. III

Degree of pollution	2
Temperature range	-5°C to +50°C
Weight	0.6kg
Output connection	HD15 (with EEPROM) for LMG sensor input

2.5.3 Accuracy

Accuracies based on: sinusoidal current, ambient temperature $23\pm 3^\circ\text{C}$, calibration interval 1 year, conductor in the middle of the clamp.

The accuracy is valid only with manual zero adjustment at the DC-Clamp prior clamp on!

The values are in $\pm(\%$ of measuring value + $\%$ of nominal input current), phase in degree

Current	Amplitude error DC to 2kHz	Phase error at 45 to 66Hz	Phase error at 1kHz
10A to 1500A	1.5%+0.1%	<0.3°	<3°

Use L45-Z26 and LMG specifications to calculate the accuracy of the complete system.

2.5.4 Connection of the sensor with LMG90/310

The use with LMG90 and LMG310 is not possible.

2.5.5 Connection of the sensor with LMG95

Use L95-Z07, internal supply via LMG and the Isensor/external shunt input. Set LMG current scaling factor appropriate to the scaling factor marked on the label on L95-Z07.

2.5.6 Connection of the sensor with LMG450

Use sensor input, , internal supply via LMG, you get the following ranges:

nominal value	31.3A	62.5A	125A	250A	500A	1000A
max. trms value	31.3A	62.5A	125A	250A	500A	1000A
max. peak value	46.9A	93.8A	188A	375A	750A	1500A

2.5.7 Connection of the sensor with LMG500

Use L50-Z14, internal supply via LMG, you get the following ranges:

nominal value	7.8A	15.6A	31.3A	62.5A	125A	250A	500A	1000A
max. trms value	7.8A	15.6A	31.3A	62.5A	125A	250A	500A	1000A
max. peak value	11.7A	23.4A	46.9A	93.8A	188A	375A	750A	1500A

2.6 Error compensated AC - current clamp 3000A (L45-Z16/-Z17)

(L45-Z17 is a set of 4x L45-Z16)

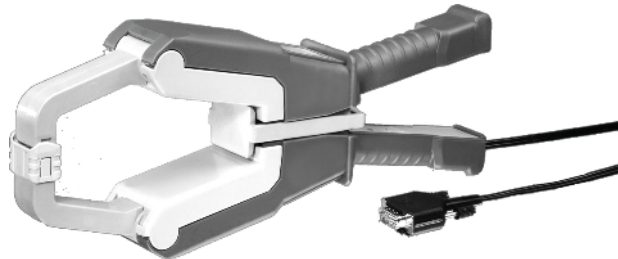

Figure 11: L45-Z16/-Z17

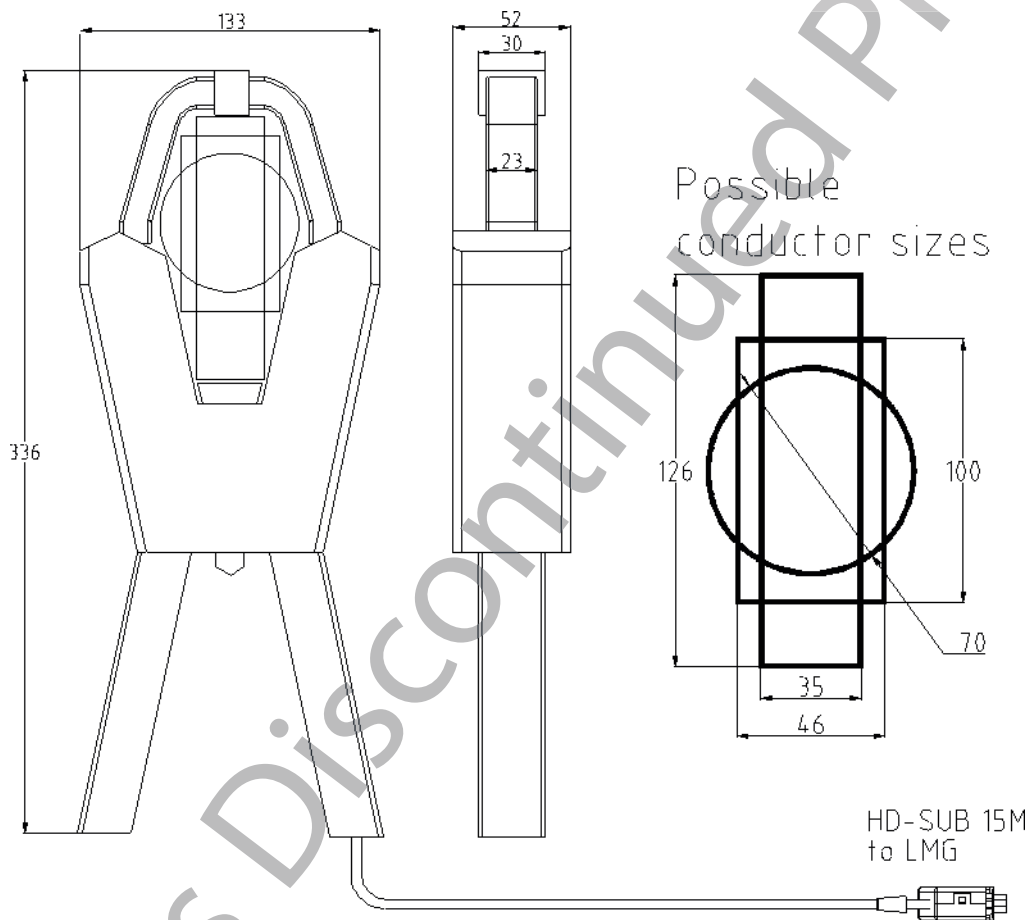

Figure 12: Dimensions of the L45-Z16/-Z17

2.6.1



Safety warning!

Always connect the sensor first to the meter, and afterwards to the device under test.
 Connecting cable without safety isolation! Avoid contact to hazardous voltage!
 Please refer to chapter 1.1: 'Safety precautions'!

2.6.2 Specifications

Nominal input current	3000A
Max. trms value	3600A
Measuring range current clamp	9000A _{pk}
Maximum input	6000A for 5min
Bandwidth	5Hz to 10kHz
Protection class	600V CAT. III
Degree of pollution	2
Temperature range	-5°C to +50°C
Weight	1,6kg
Output connection	HD15 (with EEPROM) for LMG sensor input, connection length 1.7 m

2.6.3 Accuracy

Accuracies based on: sinusoidal current, ambient temperature $23\pm 3^{\circ}\text{C}$, calibration interval 1 year, conductor in the middle of the clamp. The values are in \pm (% of measuring value + % of measuring range current clamp) and in \pm (phase error in degree)

Frequency/Hz	2Hz to 10Hz	10Hz to 45Hz	45Hz to 65Hz	65Hz to 1kHz	1kHz to 2.5kHz	2.5kHz to 5kHz	5kHz to 10kHz
Current	0.7+0.2	0.2+0.05	0.1+0.05	0.2+0.05	0.4+0.1	1+0.3	2+0.4
Phase	5	1	0.3	0.5	2	10	30

Use L45-Z16 and LMG specifications to calculate the accuracy of the complete system.

Influence of coupling mode: This current clamp can transfer only AC currents. The compensation circuit may cause a DC signal which is interpreted by the instrument as a DC current. This could cause additional errors. Therefore this clamp should only be used with the LMG setting: AC coupling. The accuracies are only valid for this case.

2.6.4 Connection of the sensor with LMG90/310

The use with LMG90 and LMG310 is not possible.

2.6.5 Connection of the sensor with LMG95

Use L95-Z07, internal supply via LMG and the Isensor/external shunt input. Set LMG current scaling factor appropriate to the scaling factor marked on the label on L95-Z07.

2.6.6 Connection of the sensor with LMG450

Use sensor input, you get the following ranges:

nominal value	100A	200A	400A	800A	1600A	3200A
max. trms value	113A	225A	450A	900A	1800A	3600A
max. peak value	281A	563A	1125A	2250A	4500A	9000A

2.6.7 Connection of the sensor with LMG500

Use L50-Z14, you get the following ranges:

nominal value	25A	50A	100A	200A	400A	800A	1600A	3200A
max. trms value	28A	56A	113A	225A	450A	900A	1800A	3600A
max. peak value	70A	141A	281A	563A	1125A	2250A	4500A	9000A

2.7 Hall current sensors, 50/100/200A (L45-Z28-HALLxx)

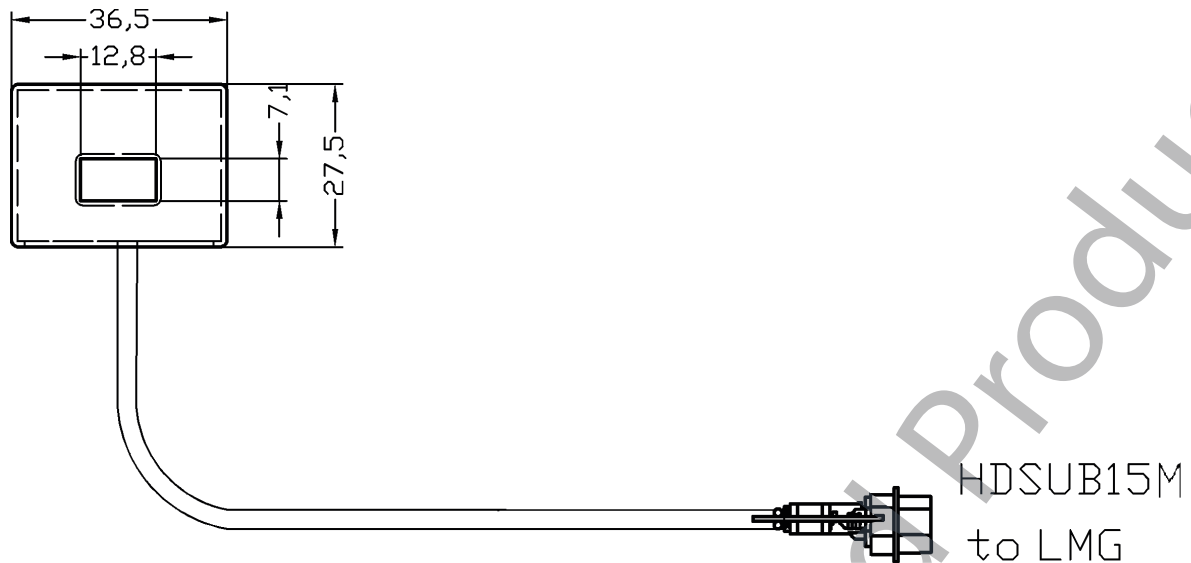

Figure 13: Dimensions of the L45-Z28-HALL50 and HALL100

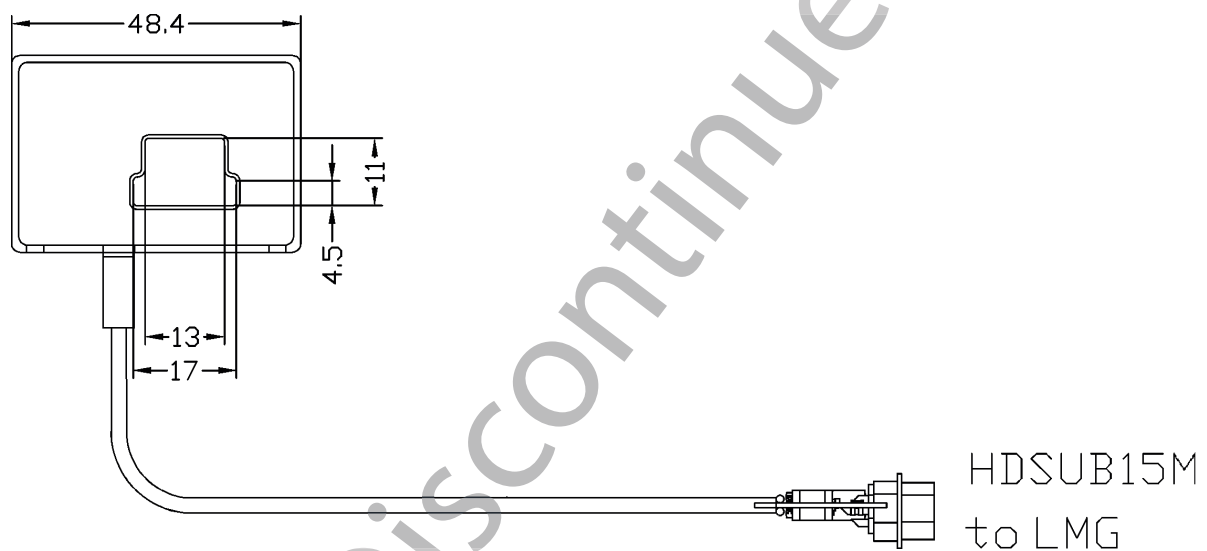

Figure 14: Dimensions of the L45-Z28-HALL200

2.7.1 Safety warning!

Always connect the sensor first to the meter, and afterwards to the device under test.
Connecting cable without safety isolation! Avoid contact to hazardous voltage!

Do not overload any current sensor with more than the measurable TRMS value!

Please refer to chapter 1.1: 'Safety precautions'!

2.7.2 Specifications and accuracies

Accuracies based on: sinusoidal current, ambient temperature $23\pm 3^{\circ}\text{C}$, calibration interval 1 year, conductor in the middle of the hall sensor.

Sensor	HALL50	HALL100	HALL200
Rated range value	35A	60A	120A
Measurable TRMS value	50A	100A	200A
Permissible peak value	70A	120A	240A
Accuracies in % of measurable TRMS value at DC .. 100Hz	±0.9	±0.7	±0.65
Linearity	0.15%	0.15%	0.15%
DC offset error at 25°C	±0.2A	±0.2A	±0.4A
DC offset thermal drift (0°C.. 70°C)	±0.5A	±0.5A	±0.5A
Response time at 90% of measurable TRMS value	<1µs	<1µs	<1µs
di/dt accurately followed	> 200A/µs	> 200A/µs	> 200A/µs
Bandwidth (-1dB)	DC to 200kHz	DC to 200kHz	DC to 100kHz

Use HALLxx and LMG specifications to calculate the accuracy of the complete system. This sensors are supplied by the HD15 sensor connector of the LMG.

The transformers are only allowed to operate with cables which - according to the printing on the cable - are designed for this individual transformer.

2.7.3 Sensor operation without supply

It is important to assure a stable power supply of the sensor before switching on the load current! The **operation** of the sensor with load current and **without supply will cause damage** of the sensor and/or of the LMG/supply unit!

To remove the LMG/supply unit from the test location without removing the sensors from the current path, disconnect the HD15 plug from the LMG and connect all of the 15pins together with ground (shield of the plug). To do this, the load current has to be switched off!

2.7.4 Connection of the sensor with LMG90/310

The use with LMG90 and LMG310 is not possible.

2.7.5 Connection of the sensor with LMG95

Use L95-Z07, internal supply via LMG and the Isensor/external shunt input. Set LMG current scaling factor appropriate to the scaling factor marked on the label on L95-Z07.

2.7.6 Connection of the sensor with LMG450

Use sensor input, you get the following ranges:

HALL50:

nominal value	1.09A	2.19A	4.38A	8.75A	17.5A	35A
---------------	-------	-------	-------	-------	-------	-----

max. trms value	1.57A	3.13A	6.25A	12.5A	25A	50A
max. peak value	2.19A	4.38A	8.75A	17.5A	35A	70A

HALL100:

nominal value	1.88A	3.75A	7.5A	15A	30A	60A
max. trms value	3.13A	6.25A	12.5A	25A	50A	100A
max. peak value	3.75A	7.5A	15A	30A	60A	120A

HALL200:

nominal value	3.75A	7.5A	15A	30A	60A	120A
max. trms value	6.25A	12.5A	25A	50A	100A	200A
max. peak value	7.5A	15A	30A	60A	120A	240A

2.7.7 Connection of the sensor with LMG500

Use L50-Z14, you get the following ranges:

HALL50:

nominal value	0.27A	0.55A	1.09A	2.19A	4.38A	8.75A	17.5A	35A
max. trms value	0.39A	0.79A	1.57A	3.13A	6.25A	12.5A	25A	50A
max. peak value	0.55A	1.09A	2.19A	4.38A	8.75A	17.5A	35A	70A

HALL100:

nominal value	0.47A	0.94A	1.88A	3.75A	7.5A	15A	30A	60A
max. trms value	0.79A	1.57A	3.13A	6.25A	12.5A	25A	50A	100A
max. peak value	0.94A	1.88A	3.75A	7.5A	15A	30A	60A	120A

HALL200:

nominal value	0.94A	1.88A	3.75A	7.5A	15A	30A	60A	120A
max. trms value	1.57A	3.13A	6.25A	12.5A	25A	50A	100A	200A
max. peak value	1.88A	3.75A	7.5A	15A	30A	60A	120A	240A

2.8 Hall current sensors, 300/500/1k/2kA (L45-Z29-HALLxx)

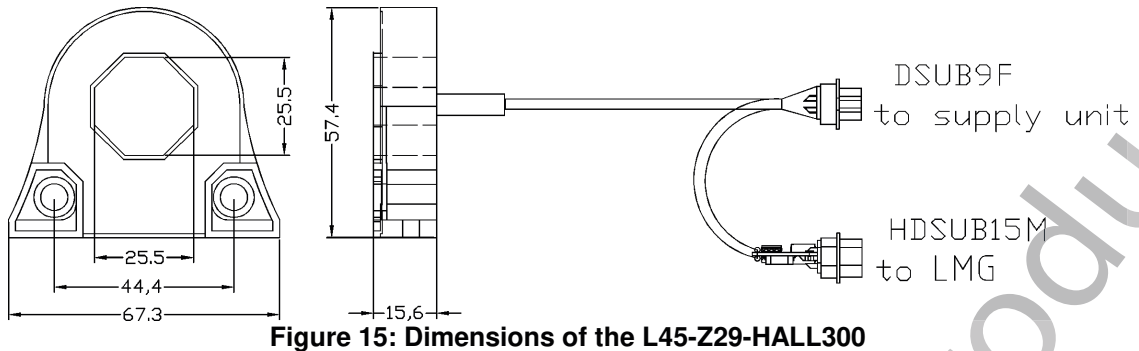

Figure 15: Dimensions of the L45-Z29-HALL300

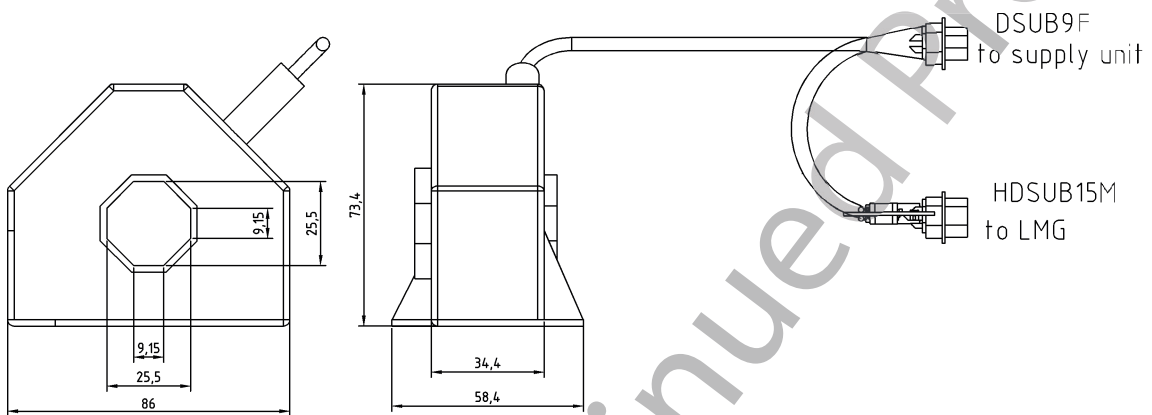

Figure 16: Dimensions of the L45-Z29-HALL500

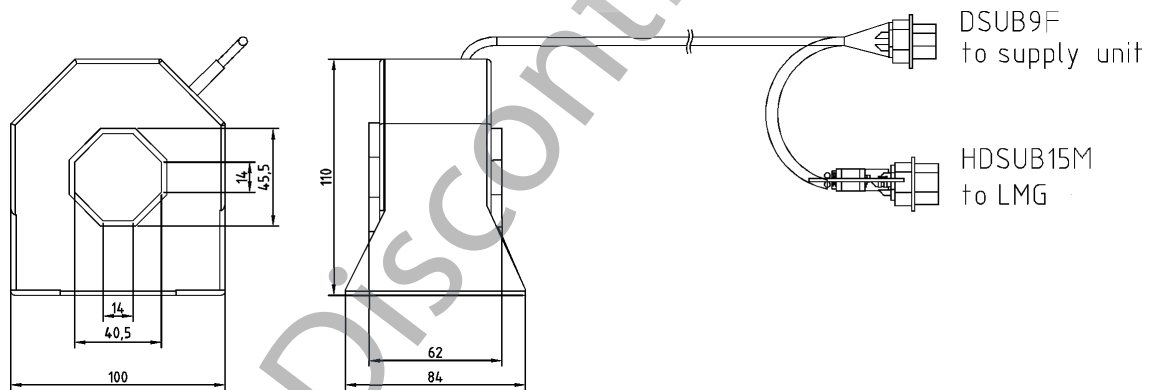

Figure 17: Dimensions of the L45-Z29-HALL1000

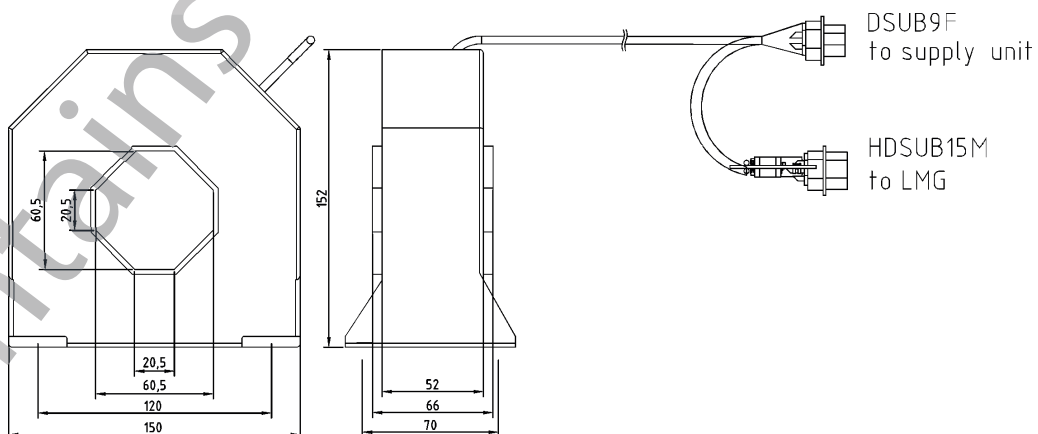

Figure 18: Dimensions of the L45-Z29-HALL2000

2.8.1 Safety warning!

Always connect the sensor first to the meter, and afterwards to the device under test. Connecting cable without safety isolation! Avoid contact to hazardous voltage!

Do not overload any current sensor with more than the measurable TRMS value!

Please refer to chapter 1.1: 'Safety precautions'!

2.8.2 Specifications and accuracies

Accuracies based on: sinusoidal current, ambient temperature $23\pm 3^{\circ}\text{C}$, calibration interval 1 year, conductor in the middle of the hall sensor.

Sensor	HALL300	HALL500	HALL1000	HALL2000
Rated range value	250A	400A	600A	1000A
Measurable TRMS value	300A	500A	1000A	2000A
Permissible peak value	500A	800A	1200A	2100A
Accuracies in % of measurable TRMS value at DC .. 100Hz	± 0.4	± 0.8	± 0.4	± 0.3
Linearity	0.1%	0.1%	0.1%	0.1%
DC offset error at 25°C	$\pm 0.4\text{A}$	$\pm 0.5\text{A}$	$\pm 2\text{A}$	$\pm 4\text{A}$
DC offset thermal drift ($0^{\circ}\text{C}.. 70^{\circ}\text{C}$)	$\pm 1.3\text{A}$	$\pm 0.6\text{A}$	$\pm 2.5\text{A}$	$\pm 1.5\text{A}$
Response time at 90% of measurable TRMS value	$< 1\mu\text{s}$	$< 1\mu\text{s}$	$< 1\mu\text{s}$	$< 1\mu\text{s}$
di/dt accurately followed	$> 100\text{A}/\mu\text{s}$	$> 100\text{A}/\mu\text{s}$	$> 50\text{A}/\mu\text{s}$	$> 50\text{A}/\mu\text{s}$
Bandwidth (-1dB)	DC..100kHz	DC..100kHz	DC..150kHz	DC..100kHz
Supply current @ $\pm 15\text{V}$	270mA	420mA	270mA	460mA

Use HALLxx and LMG specifications to calculate the accuracy of the complete system.

The transformers are only allowed to operate with cables which - according to the printing on the cable - are designed for this individual transformer.

This sensors have an additional 9 pin SUB-D connector for an external supply (for example SSU4). If you want to use your own supply, you have to use the following pins of the 9 pin SUB-D connector:

GND: Pin 3 **and** Pin 4 (always connect both)

-15V Pin 5

+15V Pin 9

Please make sure, that your own power supply can drive the needed supply current. If you offer too few current you will get distortions and other accuracy losses in your measured current without warning!

2.8.3 Sensor operation without supply

It is important to assure a stable power supply of the sensor before switching on the load current! The **operation** of the sensor with load current and **without supply will cause damage** of the sensor and/or of the LMG/supply unit!

To remove the LMG/supply unit from the test location without removing the sensors from the current path, disconnect the DSUB9 plug and the HD15 plug from the LMG and connect all of the 9pins and all of the 15pins together with ground (shield of the plugs). To do this, the load current has to be switched off!

2.8.4 Connection of the sensor with LMG90/310

The use with LMG90 and LMG310 is not possible.

2.8.5 Connection of the sensor with LMG95

The use with LMG95 is not recommended, better use: L50-Z29-Hallxx and L95-Z07. Set LMG current scaling factor appropriate to the scaling factor marked on the label on L95-Z07.

2.8.6 Connection of the sensor with LMG450

Use sensor input, you get the following ranges:

HALL300:

nominal value	7.8A	15.6A	31.1A	62.5A	125A	250A
max. trms value	9.4A	18.7A	37.5A	75A	150A	300A
max. peak value	15.6A	31.1A	62.5A	125A	250A	500A

HALL500:

nominal value	12.5A	25A	50A	100A	200A	400A
max. trms value	15.6A	31.1A	62.5A	125A	250A	500A
max. peak value	25A	50A	100A	200A	400A	800A

HALL1000:

nominal value	18.7A	37.5A	75A	150A	300A	600A
max. trms value	31.1A	62.5A	125A	250A	500A	1000A
max. peak value	37.5A	75A	150A	300A	600A	1200A

HALL2000:

nominal value	31.1A	62.5A	125A	250A	500A	1000A
max. trms value	62.5A	125A	250A	500A	1000A	2000A

max. peak value	65.6A	131A	263A	525A	1050A	2100A
-----------------	-------	------	------	------	-------	-------

2.8.7 Connection of the sensor with LMG500

The use with LMG500 is not recommended, please see L50-Z29-Hallxx

Contains Discontinued Products

2.9 Hall current sensors, 300/500/1k/2kA (L50-Z29-HALLxx)

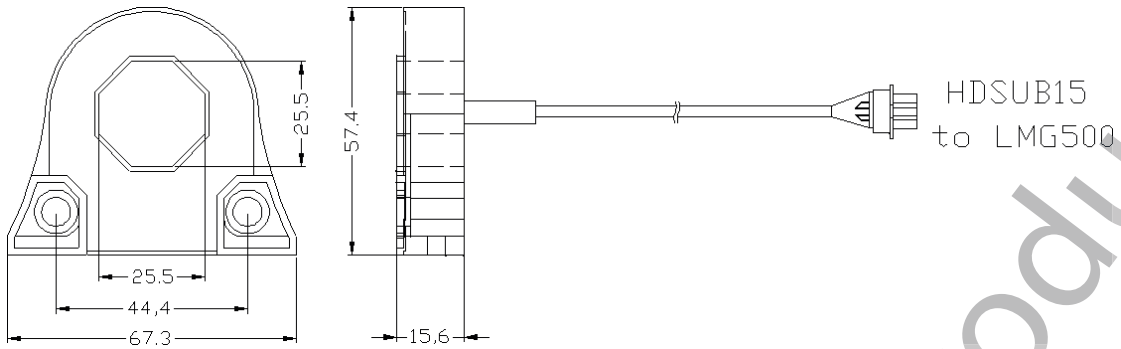

Figure 19: Dimensions of the L50-Z29-Hall300

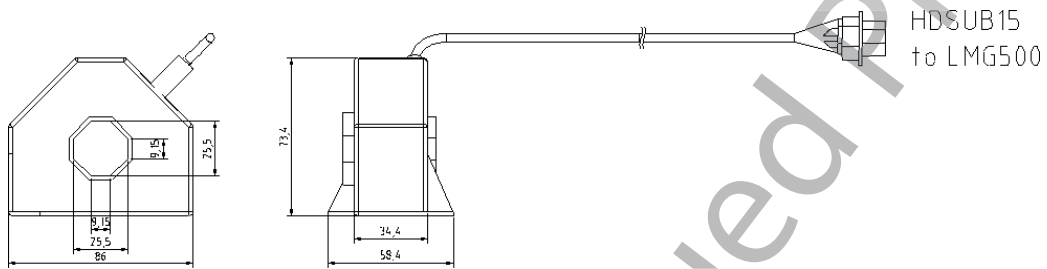

Figure 20: Dimensions of the L50-Z29-Hall500

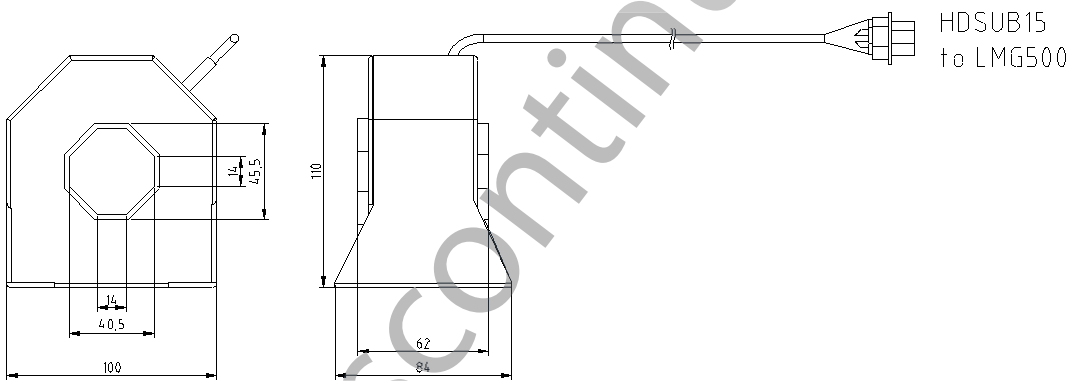

Figure 21: Dimensions of the L50-Z29-Hall1000

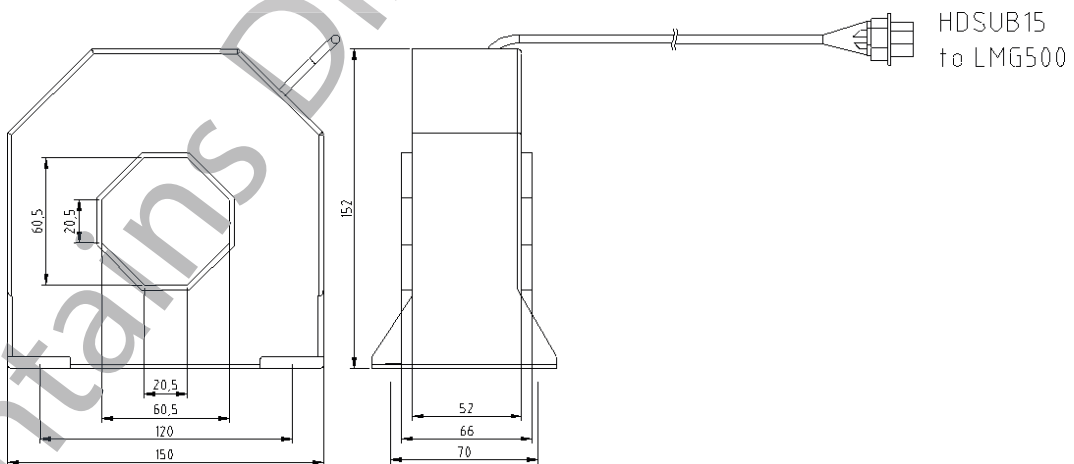

Figure 22: Dimensions of the L50-Z29-Hall2000

2.9.1 Safety warning!

Always connect the sensor first to the meter, and afterwards to the device under test. Connecting cable without safety isolation! Avoid contact to hazardous voltage!

Do not overload any current sensor with more than the measurable TRMS value!

Please refer to chapter 1.1: 'Safety precautions'!

2.9.2 Specifications and accuracies

Accuracies based on: sinusoidal current, ambient temperature $23\pm 3^{\circ}\text{C}$, calibration interval 1 year, conductor in the middle of the hall sensor.

Sensor	HALL300	HALL500	HALL1000	HALL2000
Rated range value	250A	400A	600A	1000A
Measurable TRMS value	300A	500A	1000A	2000A
Permissible peak value	500A	800A	1200A	2100A
Accuracies in % of measurable TRMS value at DC .. 100Hz	± 0.4	± 0.8	± 0.4	± 0.3
Linearity	0.1%	0.1%	0.1%	0.1%
DC offset error at 25°C	$\pm 0.4\text{A}$	$\pm 0.5\text{A}$	$\pm 2\text{A}$	$\pm 4\text{A}$
DC offset thermal drift ($0^{\circ}\text{C}.. 70^{\circ}\text{C}$)	$\pm 1.3\text{A}$	$\pm 0.6\text{A}$	$\pm 2.5\text{A}$	$\pm 1.5\text{A}$
Response time at 90% of measurable TRMS value	$< 1\mu\text{s}$	$< 1\mu\text{s}$	$< 1\mu\text{s}$	$< 1\mu\text{s}$
di/dt accurately followed	$> 100\text{A}/\mu\text{s}$	$> 100\text{A}/\mu\text{s}$	$> 50\text{A}/\mu\text{s}$	$> 50\text{A}/\mu\text{s}$
Bandwidth (-1dB)	DC..100kHz	DC..100kHz	DC..150kHz	DC..100kHz

Use HALLxx and LMG specifications to calculate the accuracy of the complete system.

The transformers are only allowed to operate with cables which - according to the printing on the cable - are designed for this individual transformer.

2.9.3 Sensor operation without supply

It is important to assure a stable power supply of the sensor before switching on the load current! The **operation** of the sensor with load current and **without supply will cause damage** of the sensor and/or of the LMG/supply unit!

To remove the LMG/supply unit from the test location without removing the sensors from the current path, disconnect the HD15 plug from the LMG and connect all of the 15pins together with ground (shield of the plug). To do this, the load current has to be switched off!

2.9.4 Connection of the sensor with LMG90/310

The use with LMG90 and LMG310 is not possible.

2.9.5 Connection of the sensor with LMG95

Use L95-Z07, internal supply via LMG and the Isensor/external shunt input. Set LMG current scaling factor appropriate to the scaling factor marked on the label on L95-Z07.

2.9.6 Connection of the sensor with LMG450

The use with LMG450 is **not possible!**

2.9.7 Connection of the sensor with LMG500

Use L50-Z14, internal supply via LMG, you get the following ranges:

HALL300:

nominal value	2A	3.9A	7.8A	15.6A	31.1A	62.5A	125A	250A
max. trms value	2.4A	4.7A	9.4A	18.7A	37.5A	75A	150A	300A
max. peak value	3.9A	7.8A	15.6A	31.1A	62.5A	125A	250A	500A

HALL500:

nominal value	3.13A	6.25A	12.5A	25A	50A	100A	200A	400A
max. trms value	3.9A	7.8A	15.6A	31.1A	62.5A	125A	250A	500A
max. peak value	6.25A	12.5A	25A	50A	100A	200A	400A	800A

HALL1000:

nominal value	4.7A	9.4A	18.7A	37.5A	75A	150A	300A	600A
max. trms value	7.8A	15.6A	31.1A	62.5A	125A	250A	500A	1000A
max. peak value	9.4A	18.7A	37.5A	75A	150A	300A	600A	1200A

HALL2000:

nominal value	7.8A	15.6A	31.1A	62.5A	125A	250A	500A	1000A
max. trms value	15.6A	31.1A	62.5A	125A	250A	500A	1000A	2000A
max. peak value	16.4A	32.8A	65.6A	131A	263A	525A	1050A	2100A

2.10 Rogowski flex sensors (L45-Z32-FLEXxx)

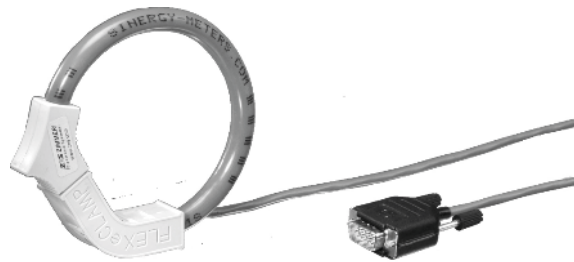

Figure 23: Dimensions of the L45-Z32-FLEX xx

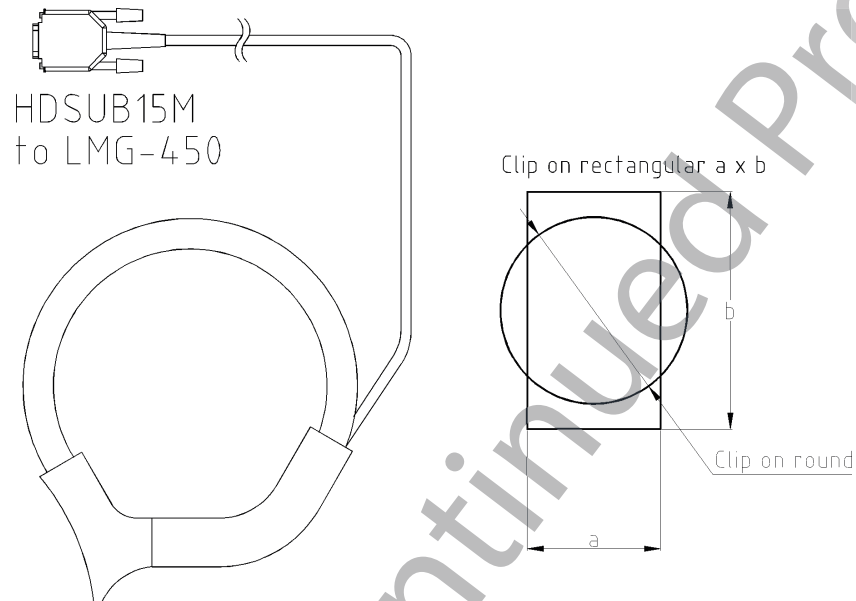

Figure 24: Dimensions of the L45-Z32-FLEX xx

2.10.1 Safety warning!

Always connect the sensor first to the meter, and afterwards to the device under test.
Connecting cable without safety isolation! Avoid contact to hazardous voltage!
Please refer to chapter 1.1: 'Safety precautions'!

2.10.2 Specifications

Sensor	FLEX 500	FLEX 1000	FLEX 3000
Rated range value	500A	1000A	3000A
Permissible peak range value	700A	1400A	4200A
Position sensitivity	±5%	±2%	±2%
Frequency range	10Hz .. 5kHz	10Hz .. 5kHz	10Hz .. 5kHz
Phase Shift (at 50/60Hz, cable in middle of the head)	0.1°	0.1°	0.1°
Rogowski sensor length	30cm	40cm	75cm
Connection cable length	2m	2m	2m
Clip on round (diameter)	75mm	110mm	200mm

Clip on rectangular (a x b)	20mm x 85mm	30mm x 120mm	60mm x 250mm
max. loops	1	1	3
Weight	100g	120g	160g
Temperature range	-20°C .. +85°C		
Protection class	600V / CATIII		
Degree of pollution	2		
Output connection	HD15 plug (with EEPROM) for LMG sensor input		

2.10.3 Accuracy

Accuracies based on: sinusoidal current, ambient temperature $23\pm 3^{\circ}\text{C}$, calibration interval 1 year, conductor in the middle of the clamp.

The values are: $\pm(\% \text{ of measuring value} + \% \text{ of rated range value})$

Frequency/Hz	10Hz to 45Hz	45Hz to 65Hz	65Hz to 1kHz	1kHz to 5kHz
FLEX xx current accuracy	0.5+1.5	0.5+0.6	0.5+1.5	5+5

Use FLEXxx and LMG specifications to calculate the accuracy of the complete system.

2.10.4 Sensor operation without supply

It is important to assure a stable power supply of the sensor before switching on the load current! The **operation** of the sensor with load current and **without supply will cause damage** of the sensor and/or of the LMG/supply unit!

To remove the LMG/supply unit from the test location without removing the sensors from the current path, disconnect the HD15 plug from the LMG and connect all of the 15pins together with ground (shield of the plug). To do this, the load current has to be switched off!

2.10.5 Connection of the sensor with LMG90/310

The use with LMG90 and LMG310 is not possible.

2.10.6 Connection of the sensor with LMG95

Use L95-Z07, internal supply via LMG and the Isensor/external shunt input. Set LMG current scaling factor appropriate to the scaling factor marked on the label on L95-Z07.

2.10.7 Connection of the sensor with LMG450

Use sensor input, internal supply via LMG, you get the following ranges:

FLEX500:

nominal value	15.6A	31.3A	62.5A	125A	250A	500A
---------------	-------	-------	-------	------	------	------

max. trms value	15.6A	31.3A	62.5A	125A	250A	500A
max. peak value	21.9A	43.8A	87.5A	175A	350A	700A

FLEX1000:

nominal value	31.3A	62.5A	125A	250A	500A	1000A
max. trms value	31.3A	62.5A	125A	250A	500A	1000A
max. peak value	43.8A	87.5A	175A	350A	700A	1400A

FLEX3000:

nominal value	93.8A	188A	375A	750A	1500A	3000A
max. trms value	93.8A	188A	375A	750A	1500A	3000A
max. peak value	131A	263A	525A	1050A	2100A	4200A

2.10.8 Connection of the sensor with LMG500

Use L50-Z14, internal supply via LMG, you get the following ranges:

FLEX500:

nominal value	3.9A	7.8A	15.6A	31.3A	62.5A	125A	250A	500A
max. trms value	3.9A	7.8A	15.6A	31.3A	62.5A	125A	250A	500A
max. peak value	5.5A	10.9A	21.9A	43.8A	87.5A	175A	350A	700A

FLEX1000:

nominal value	7.8A	15.6A	31.3A	62.5A	125A	250A	500A	1000A
max. trms value	7.8A	15.6A	31.3A	62.5A	125A	250A	500A	1000A
max. peak value	10.9A	21.9A	43.8A	87.5A	175A	350A	700A	1400A

FLEX3000:

nominal value	23.5A	46.9A	93.8A	188A	375A	750A	1500A	3000A
max. trms value	23.5A	46.9A	93.8A	188A	375A	750A	1500A	3000A
max. peak value	32.8A	65.6A	131A	263A	525A	1050A	2100A	4200A

3 LMG95 connection cables and adapter

3.1 Adapter for the use of HD15-Sensors with LMG95 (L95-Z07)

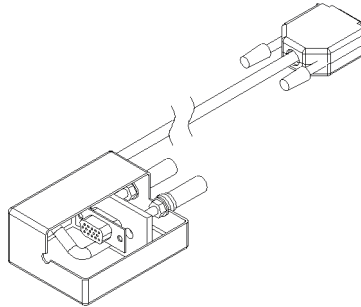

Figure 25: Adapter for the use of HD15-Sensors with LMG95 (L95-Z07)

3.1.1 Safety warning!

Always connect the sensor first to the meter, and afterwards to the device under test
Connecting cables without safety isolation! Avoid contact to hazardous voltage!
Please refer to chapter 1.1: 'Safety precautions'!

3.1.2 Specifications

suitable sensors	remarks
L45-Z26	DC current clamp 1000A
L45-Z28-HALLxx	Hall-transducer 50A, 100A, 200A
L50-Z29-HALLxx	Hall-transducer 300A, 500A, 1000A, 2000A
L45-Z32-FLEXxx	Rogowski-transducer 500A, 1000A, 3000A
PSUxx-K-L50	PSU60, -200, -400, -700
L45-Z406	
L45-Z10	better use: LMG-Z322
L45-Z16	better use: LMG-Z329

Plug the DSUB connector to LMG95 external supply and the two 4mm jacks to LMG95 ext.Shunt/I.

You can find a label with the suitable scaling factor on L95-Z07. Please set this current scaling in the range menu of the LMG95.

3.2 PSU/PCT-K-L95

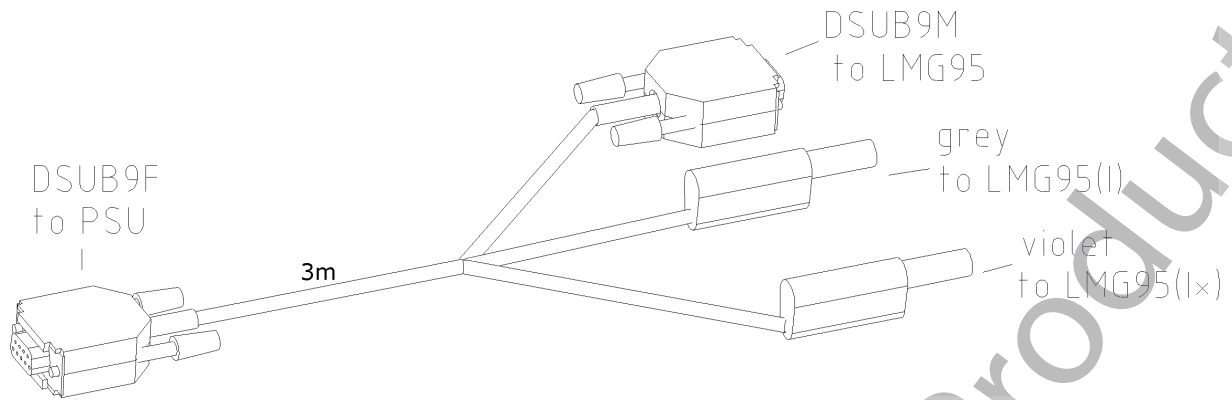

Figure 26: PSU/PCT-K-L95, for direct connection of the PSU60/200/400/700 and PCT200/600 to the current input of the LMG95

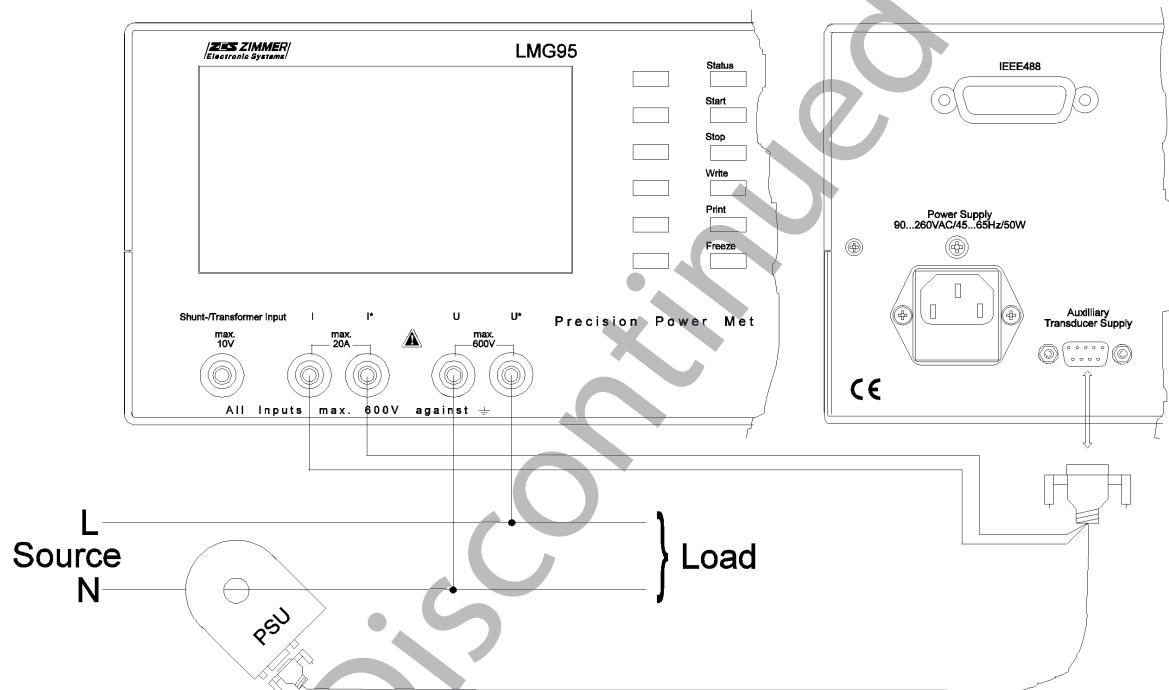

Figure 27: Connection of PSU60/200/400/700 and PCT200/600 to the LMG95

3.2.1 Safety warning!

Always connect the sensor first to the meter, and afterwards to the device under test
 Connecting cables without safety isolation! Avoid contact to hazardous voltage!
 Please refer to chapter 1.1: 'Safety precautions'!

3.2.2 Installation

No additional supply needed. Cable length between PSU/PCT and LMG: 2.5m

3.2.3 LMG95 ranges (direct current input) with PCT200I_{scale}=500

nominal value	75A	150A
max. trms value	150A	300A
max. peak value	234.5A	469A

limited by PCT200 to max. 300Apk!**3.2.4 LMG95 ranges (direct current input) with PCT600**I_{scale}=1500

nominal value	225A	450A
max. trms value	450A	900A
max. peak value	703.5A	1407A

limited by PCT600 to max. 900Apk!**3.2.5 LMG95 ranges (direct current input) with PSU200**I_{scale}=1000

nominal value	150A
max. trms value	300A
max. peak value	469A

limited by PSU200 to max. 200Apk!**3.2.6 LMG95 ranges (direct current input) with PSU400**I_{scale}=2000

nominal value	300A
max. trms value	600A
max. peak value	938A

limited by PSU400 to max. 400Apk!**3.2.7 LMG95 ranges (direct current input) with PSU700**I_{scale}=1750

nominal value	262.5A	525A
max. trms value	525A	1050A

max. peak value	820.75A	1641.5A
-----------------	---------	---------

limited by PSU700 to max. 700Apk!

3.2.8 Accuracy

Use PSU/PCT and LMG95 specifications to calculate the accuracy of the complete system.

3.2.9 Sensor operation without supply

It is important to assure a stable power supply of the sensor before switching on the load current! The **operation** of the sensor with load current and **without supply will cause damage** of the sensor and/or of the LMG/supply unit!

To remove the LMG/supply unit from the test location without removing the sensors from the current path, disconnect the DSUB9 plug and the safety laboratory plugs from the LMG and connect all of the 9pins together with ground (shield of the plug) and together with the hot-wired safety laboratory plugs. To do this, the load current has to be switched off!

4 LMG450 connection cables and adapter

The special design of all LMG450 sensors makes them very easy and comfortable to use. The HD15 SUB D plug contains the identification of the sensor type, the measuring ranges, including the needed scaling and several more parameters. The LMG450 reads this values and the meter will automatically configured to the optimum adjustments for using this special sensor. The LMG range setup is automatically taken from the sensor EEPROM. Further on we correct some of the sensor errors (transfer error, delay time, ...). So you get the best measuring results with each sensor.

4.1 BNC adapter to sensor input HD15 without EEPROM (L45-Z09)

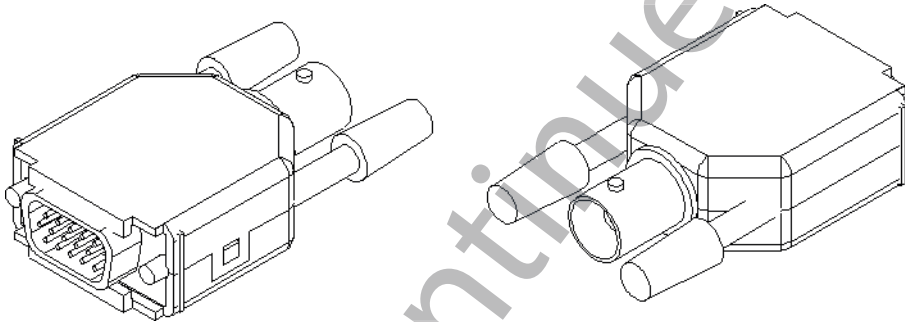

Figure 28: L45-Z09

By this adapter you can connect a voltage via a BNC cable to the LMG450 external current sensor input. This voltage has to be isolated, because the BNC screen is electrically connected to the case of the LMG450!

This is a simple electrical adapter. No values can be stored!

4.2 Adapter for isolated custom current sensors with 1A output (L45-Z22)

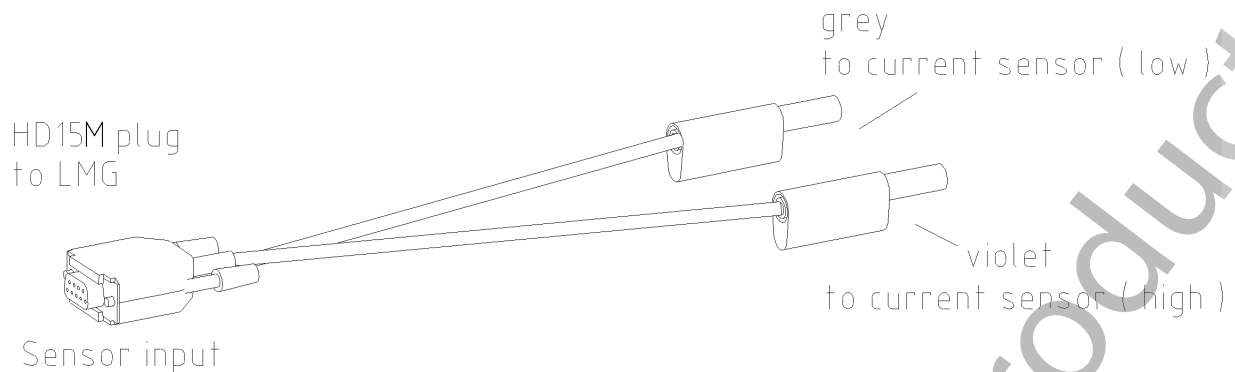

Figure 29: L45-Z22

4.2.1 Safety warning!

Use only galvanic separating current sensors! There is no potential separation in this adapter and in the LMG450 sensor input! **NOT FOR DIRECT CURRENT MEASUREMENT!!**

Please refer to chapter 1.1: 'Safety precautions'!

4.2.2 Specifications

L45-Z22 is an accessory for the precision power meter LMG450. Its benefit is the usage of isolated custom current sensors with 1A output current e.g. current transducers or clamps with the LMG450 sensor input. In comparison to the usage of the direct current inputs of the LMG450, the accessory L45-Z22 is optimized for the sensor output current of 1A and a dynamic range down to 31.25mA as full range.

Nominal input current	1A
Max. trms value	1.2A
Measuring range	3Apk
Input resistance	340mOhms
Bandwidth	DC to 20kHz
Isolation	NO ISOLATION! NOT FOR DIRECT CURRENT MEASUREMENT!
Connection	HD15 (with EEPROM) for LMG sensor input, length about 80cm

4.2.3 Accuracy

Accuracies based on: sinusoidal current, ambient temperature $23\pm 3^{\circ}\text{C}$, calibration interval 1 year. The values are: $\pm(\% \text{ of measuring value} + \% \text{ of measuring range})$

Frequency/Hz	DC to 45Hz	45Hz to 65Hz	45Hz to 5kHz	5kHz to 20kHz
Current	0.05+0.05	0.05+0.05	0.1+0.1	0.25+0.25

Use L45-Z22 and LMG specifications to calculate the accuracy of the complete system.

4.2.4 Connection of the sensor with LMG90/310

not possible

4.2.5 Connection of the sensor with LMG95

not possible

4.2.6 Connection of the sensor with LMG450

nominal value	0.03A	0.06A	0.12A	0.25A	0.5A	1A
max. trms value	0.04A	0.08A	0.15A	0.3A	0.6A	1.2A
max. peak value	0.09A	0.19A	0.375A	0.75A	1.5A	3A

4.2.7 Connection of the sensor with LMG500

not necessary, because of good current dynamic range of LMG500

Contains Discontinued Products

5 LMG500 connection cables and adapter

5.1 LMG500 current sensor adapter (L50-Z14)

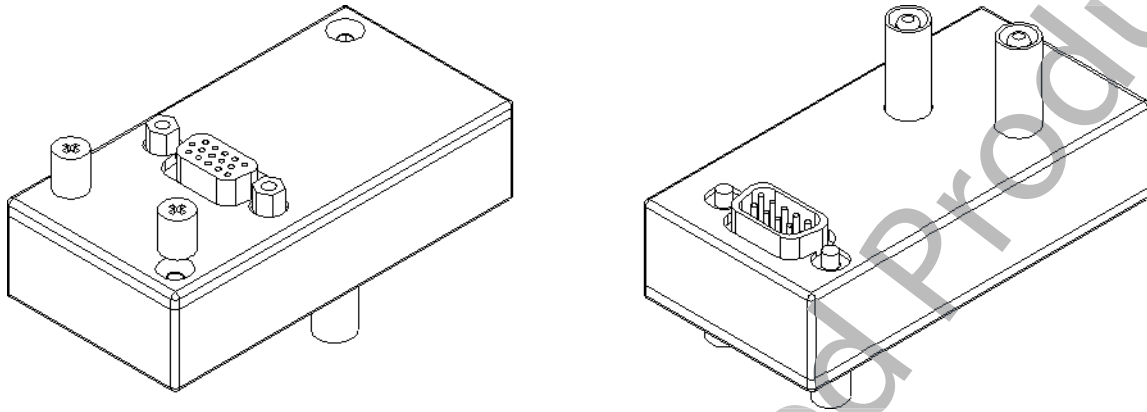

Figure 30: L50-Z14

The special design of all LMG500 sensors makes them very easy and comfortable to use. The HD15 SUB D plug contains the identification of the sensor type, the measuring ranges, including the needed scaling and several more parameters. The LMG500 reads this values and the meter will automatically configured to the optimum adjustments for using this special sensor. The LMG range setup is automatically taken from the sensor EEPROM. Further on we correct some of the sensor errors (transfer error, delay time, ...). So you get the best measuring results with each sensor.

For all LMG500 sensors the Adapter L50-Z14 is needed, because internally it is necessary to connect the system ground (CPU, Sensor supply, ...) with the ground of the measuring channel. Both signals are connected with a HD15 SUB D plug, without galvanic separation. The adapter L50-Z14 guarantees that no measuring leads are connected to the measuring channel at the same time and prevents electrical shock.

Contains Discontinued Products

6 Accessories

6.1 Sensor supply unit for up to 4 current sensors (SSU4)

The SSU4 is a supply unit to feed up to 4 pieces of current sensors. Each sensor can be supplied with +15V / 500mA, -15V / 500mA at the same time. The transducers are connected to the four 9 pin SUB-D connectors. Depending on the sensor the output signal can be accessed directly from the sensor or via the 15 pin SUB-D connector.

6.1.1 Technical data

Mains supply	85...264V, 47...440Hz, ca. 40W, Fuse 5x20mm T3.15A/250V IEC127-2/3
Protection method	IP20 according DIN40050
Protection class	I; Mains supply: Overvoltage class II and pollution degree 2 according IEC61010-1
EMC	EN55011, EN50082
Safety	EN61010
Dimensions	Desktop: 320mm (W) x 49mm (H) x 307mm (D) 19" rack: 63DU x 1HU x 360mm
Output voltage	$\pm 15V \pm 2\%$
Output current	max. 500mA on each jack
Climatic class	KYG according to DIN 40040 0°C...40°C, humidity max. 85%, annual average 65%, no dewing
Storage temperature	-20°C to +55°C
Weight	3kg

6.1.2 Technical drawings

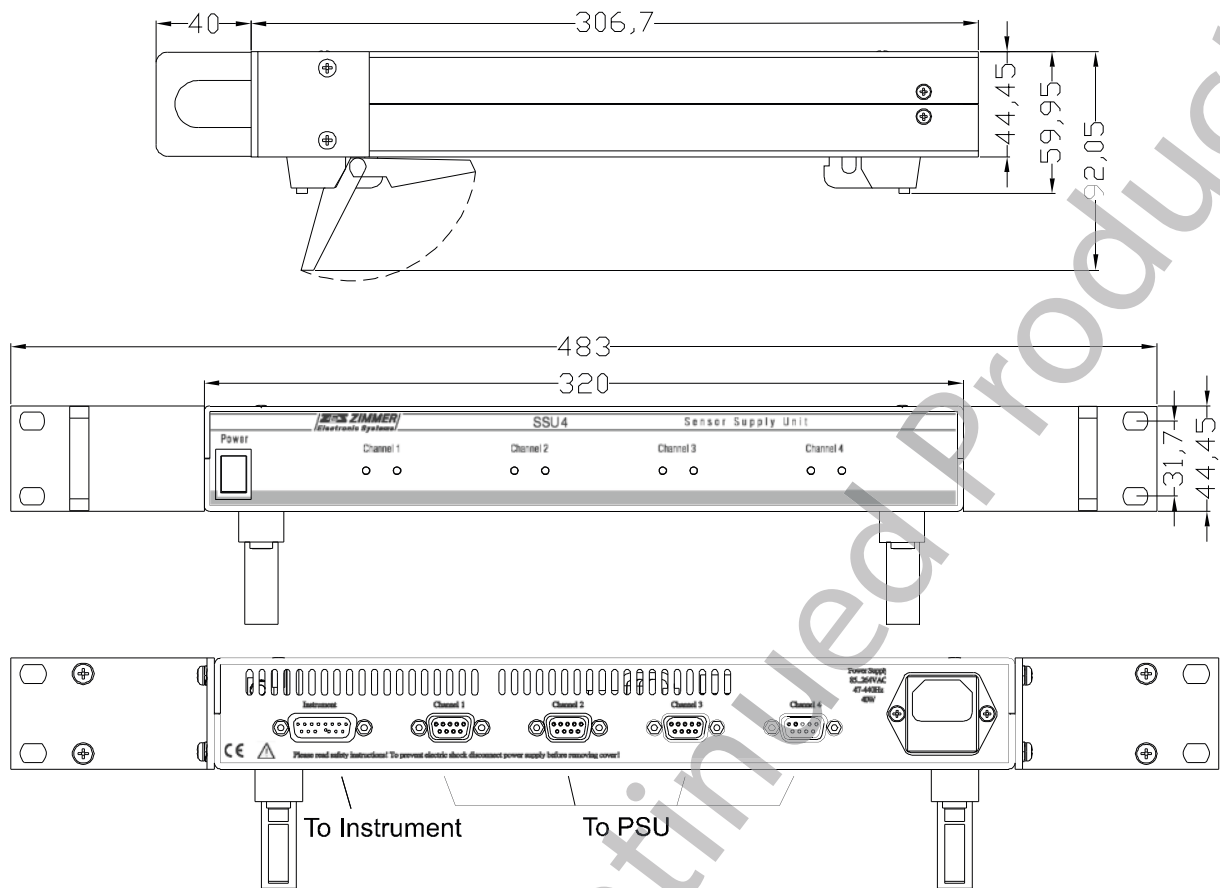

Figure 31: Dimensions of the SSU4

In the Figure 31 you see the desktop instrument, also attended the angles for rack mounting

6.1.3 Connectors

6.1.3.1 9 Pin SUB-D connectors for the sensors

Via the following connector the sensors (e.g. PSU600, L45-Z29-xxxx, ...) are connected to the SSU4 sensor supply unit. For each channel there is one connector.

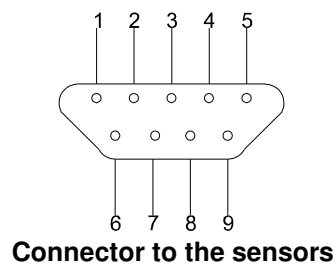

Pin	Usage
1, 2	Not used. Do not connect!
3, 4	Ground (GND)
5	-15V. max. 500mA
6	Current output signal of the sensor (max. 500mA!)
7	Not used. Do not connect!
8	Signal input to indicate a proper operation of the sensor: +15V or n.c.: The red LED is on GND: The green LED is on
9	+15V, max. 500mA

The current output signal of the sensor is connected via a 2.7Ω resistor to the corresponding channel of the 15 pin connector for the instrument. When the current returns from the instrument it is fed into ground.

6.1.3.2 15 Pin SUB-D connectors for the measuring instrument

Via the following connector the measuring instrument can be connected to the sensor supply unit:

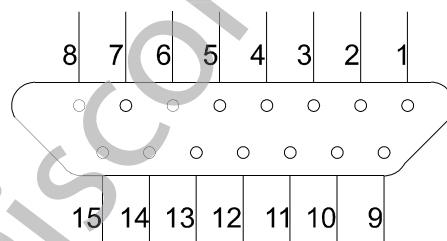

Connector to the instrument

Pin	Usage
1, 2	Current output channel 1
3, 4	Current output channel 2
5, 6	Current output channel 3
7, 8	Current output channel 4
9-15	Ground

The output current of each channel can be measured and has then to be returned to Ground.

6.1.4 Mounting

6.1.4.1 Rack mounting

Fix the two rack mounting metal sheets with the four screws at the two sides of the SSU4 case. Now you can mount it into any 19" rack.

6.1.4.2 Instrument mounting

You can mount the SSU4 directly under a LMG95 or LMG450. Please do this in following order:

- Switch off both instruments and remove all cables.
- Remove the four feet of the LMG450 or LMG95 case. To do this, just remove the four screws. The nuts are fixed inside the LMG450 or LMG95.
- Remove the four feet of the SSU4 case. The four screws are mounted into the four screw-nuts which are accessible from the top of the case. Remove also this nuts.
- With the four M4x55 screws (which are added) you mount now the four feet of the SSU4 with following orientation:

LMG95: mount the front feet in the 2nd position from the front plate.
mount the rear feet in the 2nd position from the rear plate.

LMG450: mount the front feet in the position closest to the front plate.
mount the rear feet in the position closest to the rear plate.

In both cases: The small white rubber on the feet has to be mounted in direction to the rear/front plate. The four screws are fixed into the nuts of the LMG450/LMG95 bottom (where the original feeds were fixed).

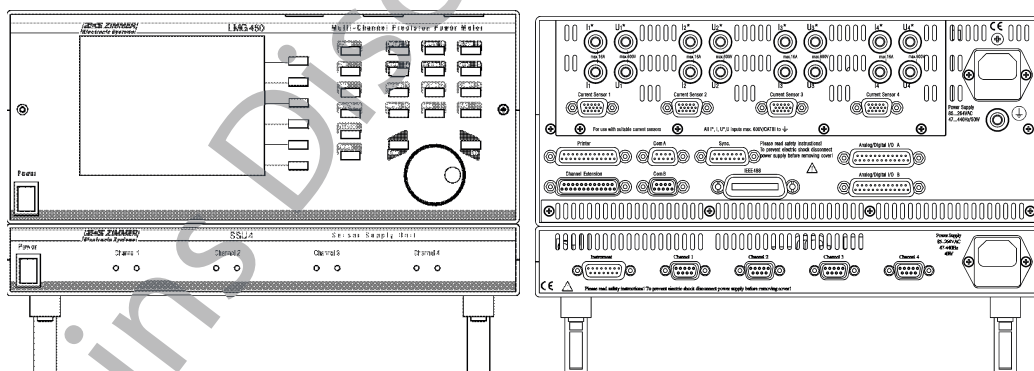

Figure 32: SSU4 mounted under LMG450

Dimensions W*D*H

320mm * 306.7mm * 224.6mm with feet, 176.9 without feet

6.1.5 SSU4 connector cables

6.1.5.1 Cable to connect measuring signal plugs of SSU4 with LMG310 current inputs (SSU4-K-L31)

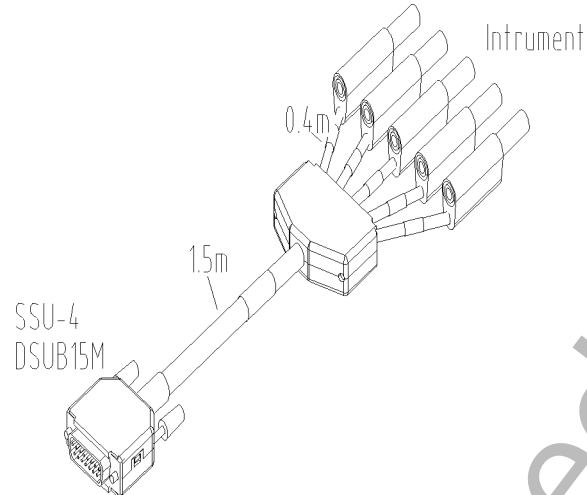

Figure 33: SSU4-K-L31, to connect measuring signal plug of SSU4 to LMG310 current inputs.

Cable to connect up to four PSU600 to the current input channels of:

- 1 LMG310
- 1 LMG310 and 1 LMG95
- 1 LMG450 (but better using PSU600-K-L45)
- 2 LMG310 in Aron wiring
- or any other amperemeter

6.1.5.2 Connection cable PSU to SSU4 (PSU-K3, K5, K10)

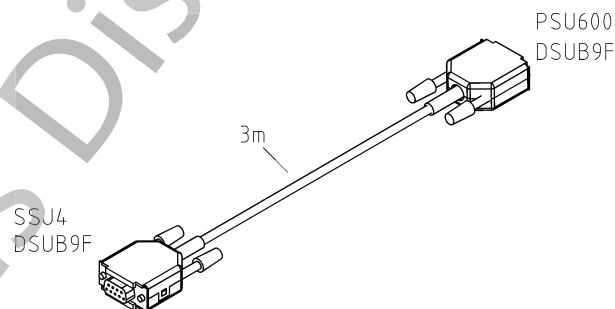

Figure 34: PSU-K3, to connect the PSU600 to the SSU4.

Connection cable from SSU4 to PSU; length 3m, 5m or 10m.

6.1.6 Modification option of SSU4 available for the use of PSU60, PSU200, PSU400 and PSU700 together with SSU4-K-L31

The modification is needed only for the use of PSU60, PSU200, PSU400 or PSU700 with SSU4-K-L31, no modification is necessary for PSUxx-K-Lxx.

The following changes concerning this documentation are done:

1. In the four connector to the sensors: **pin1** is connected with **gnd** for current return
2. The current output signal of the sensor is connected via a **0 ohms** resistor to the corresponding channel of the 15 pin connector for the instrument. When the current returns from the instrument it is fed into ground.
3. The SSU4 with modification can **not** be used with **PSU600!**

6.1.7 Modification option of SSU4 available for the use of PSU1000HF together with LMG450 and LMG500

The following changes concerning this documentation are done:

1. DSUB9 connectors for the sensors:

Pin	Usage
5	-15V. max. 1000mA
6	Current output signal of the sensor (max. 1000mA)
9	+15V, max. 1000mA

6.2 Adapter for incremental rotation speed encoders (L45-Z18)

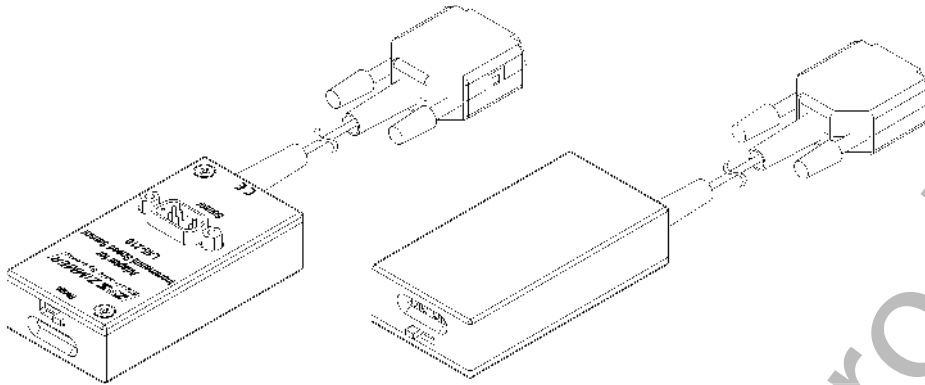

Figure 35:L45-Z18

6.2.1 Safety warning!

Always connect the sensor first to the meter, and afterwards to the device under test. Connecting cable without safety isolation! Avoid contact to hazardous voltage! Please refer to chapter 1.1: 'Safety precautions'!

6.2.2 General

This plugon adapter for LMG450 converts pulses of common industrial incremental encoders with two 90 degree phase shifted pulse outputs into analogue voltage. This voltage can be analysed graphically with high temporal resolution by using sensor input of LMG450.

Compared to this, digital encoder input of process signal interface provides only one value each measuring cycle and with L45-Z18 you get a fast, high dynamic response to changes in rotation speed!

6.2.3 Description

Incremental encoders (speed sensors) with TTL technology (supply +5V and GND) or HTL technology (supply +5V and -5V) can be connected. There are four colour coded measuring ranges of the adapter to align with different pulse rates Z of the incremental encoder and maximum revolutions per minute N_{max} .

Attention! Read measuring value I_{dc} , only this presents exact speed values according to absolute value and sign (depending on sense of rotation)! Positive output voltage is seen in case A signal leads electrically by 90° to B signal. This equates usually to clockwise rotation when looking onto the encoder shaft.

6.2.4 Ripple

As a matter of principle of frequency to voltage conversion there is a ripple at low revolution on output voltage. Built-in filters are optimised for short settling time without overshooting. In case that remaining ripple is too high, this can be reduced with the settings of LMG, for example:

- Select adjustable lowpass filter in measuring channel
- Extend the measuring cycle time
- Average over a couple of measurement cycles

Selection of the filter is always a compromise of fast reaction on variation of input signal and reduction of ripple on output signal. The user can find optimal setting weighing these antithetic approaches.

6.2.5 Incremental encoders with two 90 degree phase shifted pulse outputs

Measuring range	LED Colour	Red	Yellow	Green	Blue
Position of the slide switch adjacent of the LEDs	Unit	Left most	Left	Right	Right most
Z*Nmax (Pulse rate * max. revolution speed)	1 / min	144000	576000	2304000	9216000
Specified tolerance	% of m.value + % of m.range	$\pm(0.1+0.1)$	$\pm(0.1+0.1)$	$\pm(0.1+0.1)$	$\pm(0.1+0.1)$
Max. pulse input frequency using input A and B	Hz	2400	9600	38400	153600
Formula for "Scale"	1 / min	$1152000 / Z$	$1152000 / Z$	$1152000 / Z$	$1152000 / Z$

"Z" is the number of pulses per rotation of the used incremental encoder (speed sensor)

6.2.6 Incremental encoders with single pulse outputs

Measuring range	LED Colour	Red	Yellow	Green	Blue
Position of the slide switch adjacent of the LEDs	Unit	Left most	Left	Right	Right most
Z*Nmax (Pulse rate * max. revolution speed)	1 / min	288000	1152000	4608000	9216000
Specified tolerance	% of m.value + % of m.range	$\pm(0.1+0.1)$	$\pm(0.1+0.1)$	$\pm(0.1+0.1)$	$\pm(0.1+0.1)$
Max. pulse input frequency using input A	Hz	4800	19200	76800	153600
Formula for "Scale"	1 / min	2304000 / Z	2304000 / Z	2304000 / Z	1152000 / Z

“Z” is the number of pulses per rotation of the used incremental encoder (speed sensor)

The recognition of the rotating direction is not possible.

The output voltage is always negative if input B is left open.

The output voltage is always positive if input B is tied to pin ‘supply +5V’

6.2.7 Scaling

In range menu of LMG450 you can set the calculated scale value of the last line from above mentioned chart, depending on the pulse rate Z per rotation of the used incremental encoder. Then the revolution will be presented correctly in value 1/min on the display. The unit will however be A (or V)! Displayed 1.465kA means 1465 1/min. For further user-friendly presentation utilise capabilities of LMG450 built-in formula editor and user defined menu.

6.2.8 Pin assignment

9 pin D-Sub connector (male) to incremental encoder

Pin No.	1	2	3	4	5	6	7	8	9	Screen
Function	Supply +5V	Supply -5V	GND (on screen)	Input A	Input B	No connection (internal test pins)				Screen (on GND)

6.2.9 Pulse input A and B

Permissible input voltage: $U_{lowmin} = -30V$ at $-1.4mA$, $U_{lowmax} = +0.8V$ at $0.001mA$
 $U_{highmin} = +2V$ at $0.002mA$, $U_{highmax} = +30V$ at $1.2mA$

Input resistance: $1M\Omega$ at $0V < U_{in} < +5V$
 $22k\Omega$ at $-30V < U_{in} < +30V$

6.2.10 Encoder supply

Voltage: $\pm 5V, \pm 10\%$
Load: max. $\pm 100mA$

6.2.11 Connection of the sensor with LMG90/310/95

not possible

6.2.12 Connection of the sensor with LMG450

Plug-and-use solution like current sensors. Use current channel.

6.2.13 Connection of the sensor with LMG500

not possible, use L50-Z18

6.3 Adapter for incremental rotation speed encoders (L50-Z18)

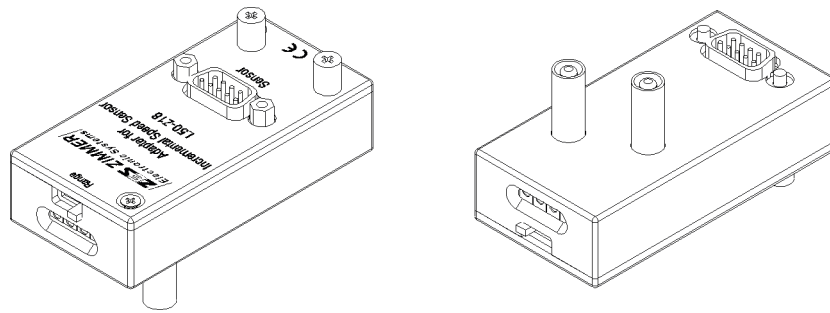

Figure 36:L50-Z18

6.3.1 Safety warning!

Always connect the sensor first to the meter, and afterwards to the device under test. Connecting cable without safety isolation! Avoid contact to hazardous voltage! Please refer to chapter 1.1: 'Safety precautions'!

6.3.2 General

This plugon adapter for LMG500 converts pulses of common industrial incremental encoders with two 90 degree phase shifted pulse outputs into analogue voltage. This voltage can be analysed graphically with high temporal resolution by using sensor input of LMG500.

Compared to this, digital encoder input of process signal interface provides only one value each measuring cycle and with L50-Z18 you get a fast, high dynamic response to changes in rotation speed!

6.3.3 Description

Incremental encoders (speed sensors) with TTL technology (supply +5V and GND) or HTL technology (supply +5V and -5V) can be connected. There are four colour coded measuring ranges of the adapter to align with different pulse rates Z of the incremental encoder and maximum revolutions per minute N_{max} .

Attention! Read measuring value I_{dc} , only this presents exact speed values according to absolute value and sign (depending on sense of rotation)! Positive output voltage is seen in case A signal leads electrically by 90° to B signal. This equates usually to clockwise rotation when looking onto the encoder shaft.

6.3.4 Ripple

As a matter of principle of frequency to voltage conversion there is a ripple at low revolution on output voltage. Built-in filters are optimised for short settling time without overshooting. In case that remaining ripple is too high, this can be reduced with the settings of LMG, for example:

- Select adjustable lowpass filter in measuring channel
- Extend the measuring cycle time
- Average over a couple of measurement cycles

Selection of the filter is always a compromise of fast reaction on variation of input signal and reduction of ripple on output signal. The user can find optimal setting weighing these antithetic approaches.

6.3.5 Incremental encoders with two 90 degree phase shifted pulse outputs

Measuring range	LED Colour	Red	Yellow	Green	Blue
Position of the slide switch adjacent of the LEDs	Unit	Left most	Left	Right	Right most
Z*Nmax (Pulse rate * max. revolution speed)	1 / min	144000	576000	2304000	9216000
Specified tolerance	% of m.value + % of m.range	$\pm(0.1+0.1)$	$\pm(0.1+0.1)$	$\pm(0.1+0.1)$	$\pm(0.1+0.1)$
Max. pulse input frequency using input A and B	Hz	2400	9600	38400	153600
Formula for "Scale"	1 / min	$1152000 / Z$	$1152000 / Z$	$1152000 / Z$	$1152000 / Z$

"Z" is the number of pulses per rotation of the used incremental encoder (speed sensor)

6.3.6 Incremental encoders with single pulse outputs

Measuring range	LED Colour	Red	Yellow	Green	Blue
Position of the slide switch adjacent of the LEDs	Unit	Left most	Left	Right	Right most
Z*Nmax (Pulse rate * max. revolution speed)	1 / min	288000	1152000	4608000	9216000
Specified tolerance	% of m.value + % of m.range	$\pm(0.1+0.1)$	$\pm(0.1+0.1)$	$\pm(0.1+0.1)$	$\pm(0.1+0.1)$
Max. pulse input frequency using input A	Hz	4800	19200	76800	153600
Formula for "Scale"	1 / min	2304000 / Z	2304000 / Z	2304000 / Z	1152000 / Z

“Z” is the number of pulses per rotation of the used incremental encoder (speed sensor)

The recognition of the rotating direction is not possible.

The output voltage is always negative if input B is left open.

The output voltage is always positive if input B is tied to pin ‘supply +5V’

6.3.7 Scaling

In range menu of LMG500 you can set the calculated scale value of the last line from above mentioned chart, depending on the pulse rate Z per rotation of the used incremental encoder. Then the revolution will be presented correctly in value 1/min on the display. The unit will however be A (or V)! Displayed 1.465kA means 1465 1/min. For further user-friendly presentation utilise capabilities of LMG500 built-in formula editor and user defined menu.

6.3.8 Pin assignment

9 pin D-Sub connector (male) to incremental encoder

Pin No.	1	2	3	4	5	6	7	8	9	Screen
Function	Supply +5V	Supply -5V	GND (on screen)	Input A	Input B	No connection (internal test pins)				Screen (on GND)

6.3.9 Pulse input A and B

Permissible input voltage: $U_{lowmin} = -30V$ at $-1.4mA$, $U_{lowmax} = +0.8V$ at $0.001mA$
 $U_{highmin} = +2V$ at $0.002mA$, $U_{highmax} = +30V$ at $1.2mA$

Input resistance: $1M\Omega$ at $0V < U_{in} < +5V$
 $22k\Omega$ at $-30V < U_{in} < +30V$

6.3.10 Encoder supply

Voltage: $\pm 5V$, $\pm 10\%$
Load: max. $\pm 100mA$

6.3.11 Connection of the sensor with LMG90/310/95

not possible

6.3.12 Connection of the sensor with LMG450

not possible, use L45-Z18

6.3.13 Connection of the sensor with LMG500

Plug-and-use solution like current sensors. Use current channel.

6.4 Synchronisation adapter with adjustable lowpass filter (L50-Z19)

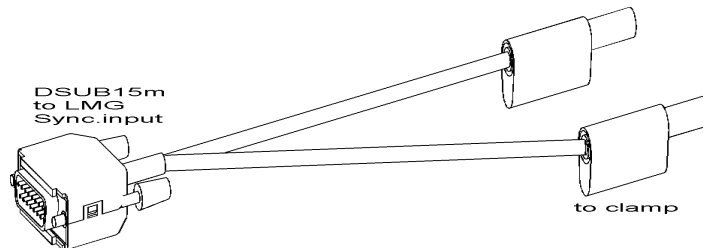

Figure 37:L50-Z19

6.4.1 Safety warning!

- 1.) first connect the clamp to L50-Z19
- 2.) connect L50-Z19 to LMG500 Sync.input and switch the power meter on
- 3.) then connect the clamp to the device under test.

Synchronisation adapter without safety isolation! Only for current clamps with galvanic isolation! NO DIRECT CONNECTION TO ANY EXTERNAL VOLTAGES!!

Please refer to chapter 1.1: 'Safety precautions'!

L50-Z19 is an accessory for the precision power meter LMG500. It can be used with any $xxA:1A$ current clamp, e.g. LMG-Z325, LMG-Z326, LMG-Z322 or LMG-Z329. A burden resistor, a high sensitivity amplifier and a 8th order Butterworth lowpass filter are included in the DSUB15 plug to assure stable synchronisation to any disturbed signal.

It simplifies the synchronisation to the fundamental current frequency of a frequency inverter output. It needs about $100\mu A$ fundamental current at the signal input. That means with a $1000A:1A$ current clamp it is possible to detect the fundamental in a wide current range from $100mA$ to $1000A$. If the fundamental current is lower than $100mA$, several load current windings in the clamp can be used to enlarge the sensitivity or use an other clamp with $100A:1A$ ratio. LMG500 settings in the measure menu: set 'Sync' to 'ExClmp' and adjust the lowpass corner frequency.

Important: L50-Z19 can be configured only in Group A, if it is configured in Group A, it can be used in Group B as well via 'Sync ext.'

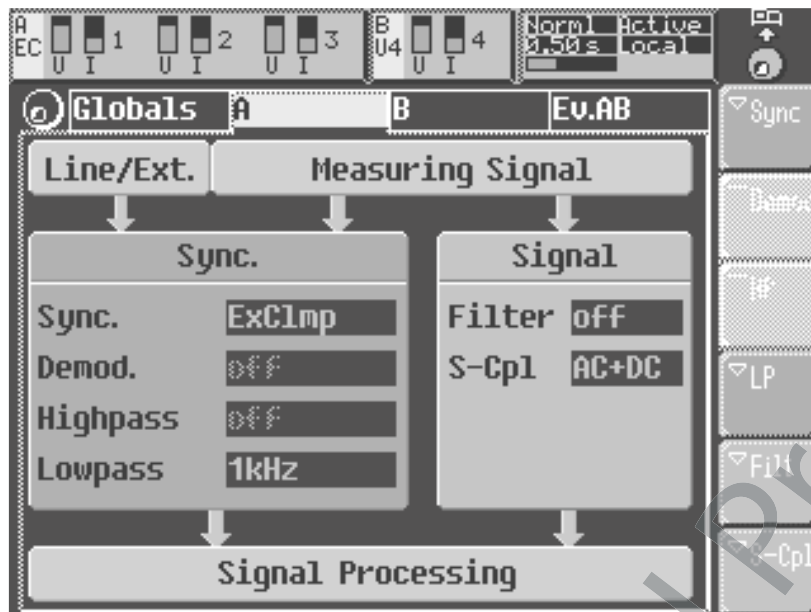

Figure 38:L50-Z19

Select a filter with a lowpass frequency bigger than every possible fundamental frequency and(!) lower than every possible switching frequency, under all conditions of starting, breaking and acceleration of the motor.

6.4.2 Specifications

filter name	200Hz	500Hz	1kHz	2kHz	5kHz	10kHz	20kHz
-3dB corner frequency	312.5Hz	625Hz	1.25kHz	2.5kHz	5kHz	10kHz	20kHz
filter type	8th order Butterworth						
min. current for stable synchronisation	about 100uA						
max. current	1A _{rms}						
isolation	NO ISOLATION! (see safety warning)						
connection length	about 50cm (but can be extended with usual safety laboratory leads)						

6.4.3 Connection of the sensor with LMG90/310/95/450

not possible

6.5 Ethernet Adapter (L95-Z318, L45-Z318, L50-Z318, LMG-Z318)

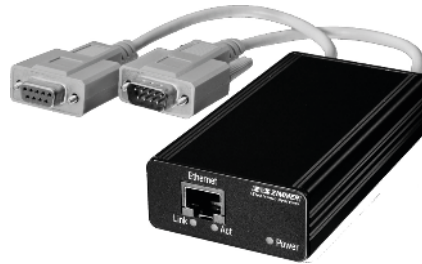

Figure 39: L95-Z318, L45-Z318, L50-Z318 - supply via LMG

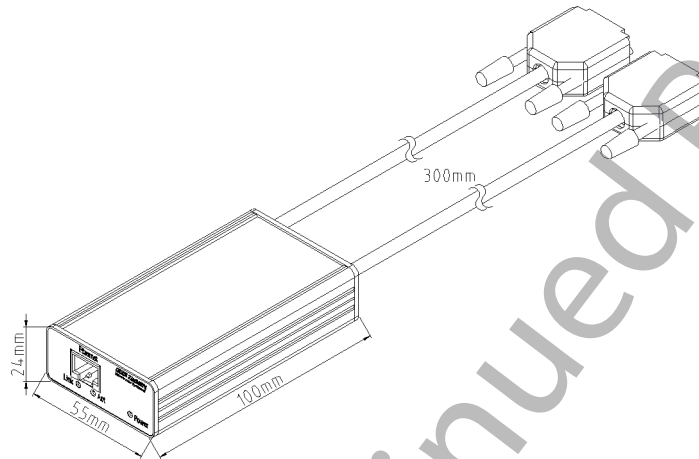

Figure 40: L95-Z318, L45-Z318, L50-Z318 - supply via LMG



Figure 41: LMG-Z318 - external supply via wall wart

This LAN adapter Z318 is useful for the communication with a power meter LMG located anywhere in a local area network LAN via a virtual COM port simulation. The communication is transmitted by the driver over LAN to the LMG for user purposes in the same way as e.g. the direct connection of PC/COM1 to LMG/COMa. The power meter LMG will be accessible via this virtual COM port. Perfect suitable for LMG Control software.

6.5.1 Safety warning!

Please refer to chapter 1.1: 'Safety precautions'!

6.5.2 System requirements, hardware specifications

- Windows XP home / Windows XP professional / Windows7 / 32bit or 64bit.
For other operating systems (including Windows: 98 / 2000 / NT /Vista, Linux: Debian / Mandriva / RedHat / Suse / Ubuntu) see <http://www.digi.com> -> support -> drivers and download the driver appropriate for your operating system for 'Digi Connect SP'.
- auto-sensing to 10/100 Mbit/s Ethernet
- throughput up to 230.400 baud
- data flow control with RTS/CTS, hardware reset with 'break'
- data throughput with LMG95/450/500
 - binary mode: about 3000 measuring values (trms, ac, dc, ..., harmonics, flicker, sample values, ...) per second!
 - ascii mode: about 1000 measuring values per second

6.5.3 Connection of the adapter L95-Z318 with LMG95 / LMG95e

- Plug the connector of L95-Z318 labeled with „to LMG's COM B conn.“ to the LMG95 / LMG95e COM B jack.
- Plug the connector of L95-Z318 labeled with „supply“ to the LMG95 / LMG95e auxiliary transducer supply jack, if your application uses the supply jack e.g. for PSU600, then use LMG-Z318 with external supply via wall wart.
- Switch on the power meter and connect the LAN cable.
- assure that the LMG firmware is 3v136 or newer for LMG95, 5v136 or newer for LMG95e

6.5.4 Connection of the adapter L45-Z318 with LMG450

- Plug the connector of L45-Z318 labeled with „to LMG's COM B conn.“ to the LMG450 COM B jack.

- Plug the connector of L45-Z318 labeled with „supply“ to one of the LMG450 current clamp 1/2/3/4 jacks whichever is free, if your application uses four current sensors, then use LMG-Z318 with external supply via wall wart.
- Switch on the power meter and connect the LAN cable.
- assure that the LMG firmware is 2v121 or newer

6.5.5 Connection of the adapter L50-Z318 with LMG500

- Plug the connector of L50-Z318 labeled with „to LMG’s COM B conn.“ to the LMG500 COM B jack.
- Plug the connector of L50-Z318 labeled with „supply“ to one of the LMG500 sensor ID jacks whichever is free.
- Switch on the power meter and connect the LAN cable.
- assure that the LMG firmware is 4v077 or newer

6.5.6 Connection of the adapter LMG-Z318 with any LMGxx

- Connect the DSUB9 jack of LMG-Z318 with a 1:1 serial connection cable to LMGs COMa.
- Connect the wall wart with power input of LMG-Z318.
- Switch on the power meter and connect the LAN cable.

6.5.7 Configure the LAN connection with the Realport setup wizard

- You will find the setup wizard on the ZES support CD under driver\z318 or on the webpage <http://www.zes.com>. Start setup32.exe for 32-bit systems or setup64.exe for 64-bit systems.

Press ‘next’, the wizard tries to find the ethernet adapter. If it is not found, perform a factory reset of the ethernet adapterbox to remove possible given prior IP address and wait for about 1 minute before searching again.

Factory Reset:

- switch power off
- hold the reset switch
- switch power on
- hold the reset switch for at least 30 sec.
- release the reset switch, the ethernet adapter will reboot.

This is the most important point in the installation. If the wizard still can not find the Z318 in your LAN, please ask your system administrator before you contact the support hotline of ZES. The support engineers of ZES will need a lot of detailed information about your local network to consult.

- If the wizard found one or more devices choose the appropriate one and press 'next'.
- Take care, that Z318 gets the same IP address after its next startup. Configure your local DHCP server that the fix MAC address of Z318 gets everytime the same IP address or set a fix (and free!) IP address manually. This is important, because in the next step you assign a virtual COM port to this IP address and if the IP address was different after the next startup, the virtual COM port would be not available.
- Select: 'add a new device'. It might be necessary to remove previous installed drivers with 'remove an existing device'.

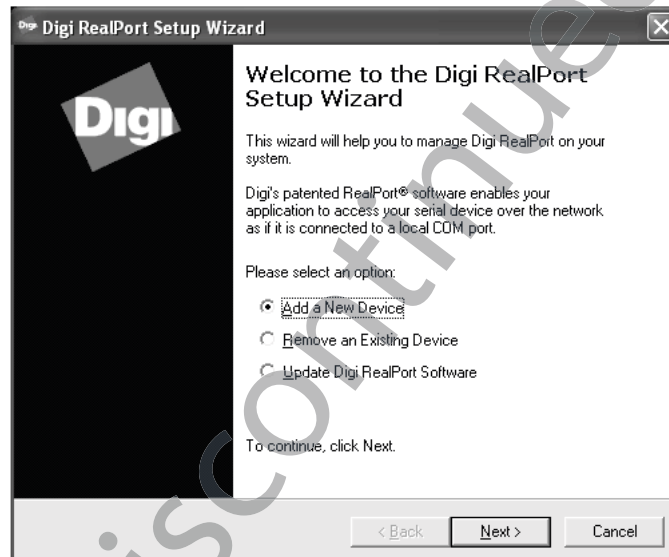

Figure 42

- Select the device ..



Figure 43

- .. and assign a virtual COM port:

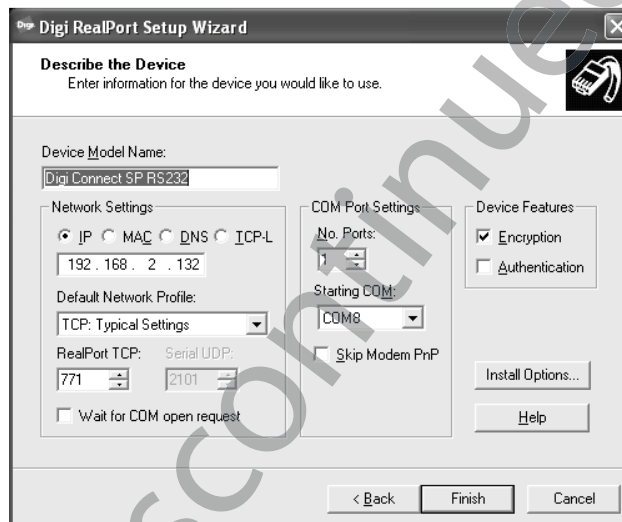

Figure 44

The power meter LMG is now accessible via this virtual COM port.

6.5.8 Configuration and Management by web interface

- Start your Browser and login to the IP address obtained to your LAN adapter Z318 <http://192.168.x.xx/login.htm> with the username 'root' and the password 'dbps':

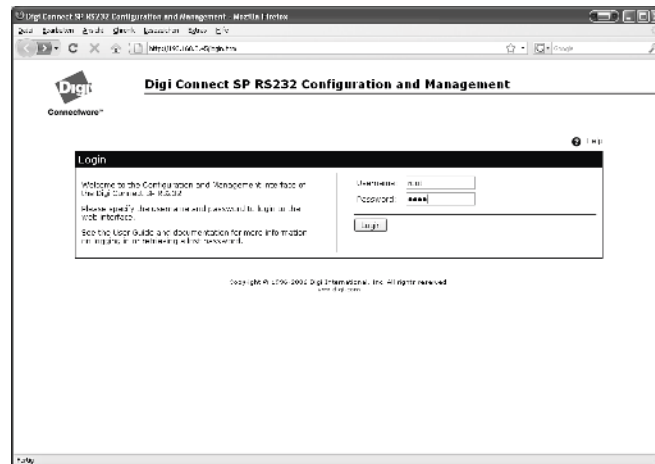

Figure 45

- Here you can manage the settings in a comfortable way: e.g. check MAC Address, IP Adress, firmware update and so on.

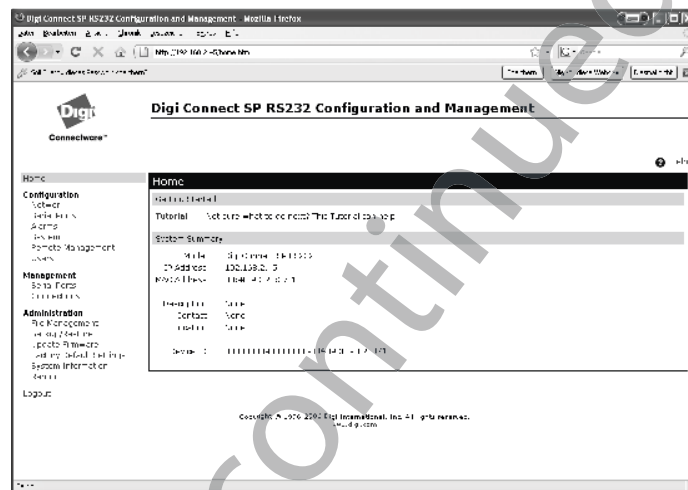

Figure 46

6.5.9 Troubleshooting

The following problems may appear while installing the ethernet adapter. If the problem remains after checking the following points, please contact ZES at sales@zes.com or ++49 6171 628750

- please check all connections: supply, RS232, LAN, in case of LMG-Z318 and LMGx COMa: use 1:1 serial cable, no nullmodem
- connect the ethernet adapter to the power supply, press reset, wait for about 1 minute and try again
- switch off your antivirus protection software, the firewall may block the communication

7 FAQ - frequently asked questions / Knowledge base

7.1 Example of an error calculation: general derivation

The calculations illustrate how to calculate the errors of U, I or P when using an external sensor. The following parameters of the measurement are given:

The measurement is made with a LMG95, the accuracies of the channels are in $\pm(\%$ of measuring value + $\%$ of measuring range):

Frequency/Hz	45 to 65
Voltage	0.01+0.02
Current	0.01+0.02
Active Power	0.015+0.02

The clamp with which is measured is the LMG-Z322 with an accuracy of:

Current	Amplitude error	Phase error
10A to 200A	1.5%	2°
200A to 1000A	0.75%	0.75°
1000A to 1200A	0.5%	0.5°

Ratio of 1000:1.

At the I channel we are using a scaling of 1000 to get the correct currents at the display. In the following examples all values are calculated for the primary side, what means on measured signal level. The readings are:

U_{rms} : 230.000V, range 250V \Rightarrow range peak value 400V

I_{rms} : 100.000A primary \Rightarrow 0.1A secondary; range 150mA \Rightarrow range peak value 469mA
calculated back to the primary side: range 150A \Rightarrow range peak value 469A

f: 50Hz

φ : 45°

P: 16.2635kW, range 37.5kW \Rightarrow range peak value 187.6kW

AC coupling mode for the signal is selected (what means you have no errors because of the DC offset of the signal).

From the table above the following errors of the LMG95 itself for voltage and current can be determined (using the peak values of the respective measuring range):

$$\Delta U = \pm(0.01\% \text{ of } R_{dg.} + 0.02\% \text{ of } R_{ng.}) = \pm(0.023V + 0.08V) = \pm 0.103V$$

$$\Delta I_{LMG95} = \pm(0.01\% \text{ of } R_{dg.} + 0.02\% \text{ of } R_{ng.}) = \pm(0.01A + 0.0938A) = \pm 0.1038A$$

$$\Delta P_{LMG95} = \pm(0.015\% \text{ of } R_{dg.} + 0.02\% \text{ of } R_{ng.}) = \pm(0.00244kW + 0.03752kW) = \pm 0.03996kW$$

Additional to these three errors there is the error caused by the current clamp. First the amplitude error which will be added to the ΔI_{LMG95} :

$$\Delta I_{clamp} = \pm(1.5\% \text{ of } rdg.) = \pm 1.5A$$

So you get a total current error of:

$$\Delta I_{total} = \Delta I_{LMG95} + \Delta I_{clamp} = \pm 1.6038A$$

The second error which is caused by the clamp is the error of the additional phase shift of 2° . This error will influence the active power. In this example the power can be calculated as:

$$P = U * I * \cos \varphi$$

So the total differential gives you the error:

$$\Delta P_{clamp} = \left| \frac{\partial P}{\partial U} * \Delta U \right| + \left| \frac{\partial P}{\partial I} * \Delta I_{total} \right| + \left| \frac{\partial P}{\partial \varphi} * \Delta \varphi \right|$$

you get:

$$\Delta P_{clamp} = |I * \cos \varphi * \Delta U| + |U * \cos \varphi * \Delta I_{total}| + |-U * I * \sin \varphi * \Delta \varphi|$$

At this point only the errors of the clamp are used, the errors of the LMG are already calculated:

$$\Delta U = 0!$$

$$\Delta I = \Delta I_{clamp}$$

$$\Delta \varphi = 2^\circ: \frac{2^\circ * 2\pi}{360^\circ} = 0.035 \text{ rad.}$$

$$\text{For the angles you have to use the radient: } 45^\circ = \frac{\pi}{4} \text{ rad}$$

$$\begin{aligned}\Delta P_{clamp} &= \left| 100A * \cos \frac{\pi}{4} * 0.0V \right| + \left| 230V * \cos \frac{\pi}{4} * 1.5A \right| + \left| -230V * 100A * \sin \frac{\pi}{4} * 0.035 \right| \\ &= |0.0W| + |243.95W| + |-569.22W| = 813.17W\end{aligned}$$

At this point the error values caused by the clamp should be marked:

The amplitude error of the clamp 243.95W and the phase shift causes 569.22W, what means 813.17W error are caused by the clamp.

The total error of the active power is:

$$\Delta P_{total} = \Delta P_{LMG95} + \Delta P_{clamp} = \pm(0.03996kW + 0.81317kW) = 0.85313kW$$

The relative error of the active power is:

$$\Delta P_{relative} = \frac{\Delta P_{total}}{P} = 0.0525 \hat{=} 5.25\%$$

7.1.1 Improving the accuracy

If you use a current clamp like in this example with a nominal current of 1000A and your current is only 10% what means 100A a simple trick to increase the accuracy is to wind the conductor several times through the clamp. In the example the accuracy of the clamp changes with three windings to 0.75%, because of the primary current of 300A, the phase shift is 0.75°. The next example of calculation is done for three windings:

U_{trms} : 230.000V, range 250V \Rightarrow range peak value 400V

I_{trms} : Scaling $\frac{1000}{3} = 333.333$, what means all current values are divided by 3, even the errors! The ratio of the clamp stays at 1000:1!

Values: 300.000A primary \Rightarrow 0.3A secondary; range 300mA \Rightarrow range peak value 0.938A calculated back to the primary side: range 100A \Rightarrow range peak value 312.7A

f: 50Hz

φ : 45°

P: 16.2635kW, range 25kW \Rightarrow range peak value 125.080kW

$$\Delta U = \pm(0.01\% \text{ of } R_{dg.} + 0.02\% \text{ of } R_{ng.}) = \pm(0.023V + 0.08V) = \pm 0.103V$$

$$\Delta I_{LMG95} = \pm(0.01\% \text{ of } R_{dg.} + 0.02\% \text{ of } R_{ng.}) = \pm(0.01A + 0.06254A) = \pm 0.07254A$$

$$\Delta P_{LMG95} = \pm(0.015\% \text{ of } R_{dg.} + 0.02\% \text{ of } R_{ng.}) = \pm(0.00244kW + 0.02502kW) = \pm 0.027456kW$$

$\Delta I_{clamp} = \pm(0.75\% \text{ of primary current} = \text{in this case the "reading"}) = \pm 2.25A$, now with the scaling this error is divided by 3 as well, what means:

$$\Delta I_{clamp} = \pm(0.75\% \text{ of Rdg.}) = \pm 0.75A$$

$$\Delta I_{total} = \Delta I_{LMG95} + \Delta I_{clamp} = \pm 0.82254A$$

Again the total differential has to be used, but now with the following values:

$$\Delta U = 0!$$

$$\Delta I = \Delta I_{clamp}$$

$$\Delta \varphi = 0.75^\circ: \frac{0.75^\circ * 2\pi}{360^\circ} = 0.013 \text{ rad.}$$

With this the error of the clamp of the active power is:

$$\begin{aligned} \Delta P_{clamp} &= \left| 100A * \cos \frac{\pi}{4} * 0.0V \right| + \left| 230V * \cos \frac{\pi}{4} * 0.75A \right| + \left| -230V * 100A * \sin \frac{\pi}{4} * 0.013 \right| \\ &= 333.40W \end{aligned}$$

$$\Delta P_{total} = \Delta P_{LMG95} + \Delta P_{clamp} = \pm(0.027456kW + 0.33340kW) = 0.360856kW$$

The relative error of the active power is:

$$\Delta P_{relative} = \frac{\Delta P_{total}}{P} = 0.0222 \hat{=} 2.22\%$$

With this simple trick the error of the current amplitude could be reduced by 51.2%. The error of the active power even by 42.3%.

7.2 Example of an error calculation: LMG95 with external shunt

Particularly with regard to the standby power measurements compliant to EN62301 and ENERGY STAR it might be profitable and necessary to use an external shunt to increase the current dynamic and accuracy at low currents. This example shows how to calculate the measuring tolerance of the complete system consisting of LMG95 and the external shunt LMG-SH100.

- **External shunt**

LMG-SH100, 100ohms, $\pm 0.15\%$

- **Voltage measurement**

$U_{\text{eff}}=230\text{V}$

LMG95 $U_{\text{range}}=250\text{V} / 400\text{Vpk}$ (range spec.: see documentation of LMG95)

(in 115V supply networks: $U_{\text{range}}=130\text{V} / 200\text{Vpk}$, the remaining calculation is the same)

- **Current measurement**

$I_{\text{eff}}=4\text{mA}$

LMG95 $I_{\text{range}}=5\text{mA} / 15.63\text{mApk}$ (range spec.: see documentation of LMG-SHxx)

LMG95 I measuring accuracy: $\pm(0.01\%$ of measuring value $+0.02\%$ of measuring range)

- **Power measurement**

$\text{PF}=0.1$

$f=50\text{Hz}$ (or 60Hz)

$S=0.92\text{VA}$

$P=92\text{mW}$

LMG95 $P_{\text{range}}=U_{\text{range}}*I_{\text{range}}=400\text{V}*15.63\text{mA}=6.252\text{W}$

LMG95 P measuring accuracy: $\pm(0.015\%$ of measuring value $+0.01\%$ of measuring range)

- **Tolerance of current and power measurement**

Because the shunt tolerance is a purely scaling error without a term of measuring range, the error analysis can be simplified to the following calculation:

	<i>shunt error term</i>	<i>LMG error of meas.value</i>	<i>LMG error of meas.range</i>
ΔI	$= \pm(0.15/100*4\text{mA}$	$+ 0.01/100*4\text{mA}$	$+ 0.02/100*15.63\text{mA})$
	$= \pm(6\text{uA}$	$+ 0.4\text{uA}$	$+ 3.126\text{uA})$
	$= \underline{\underline{\pm 9.526\text{uA}}}$		
ΔP	$= \pm(0.15/100*92\text{mW}$	$+ 0.015/100*92\text{mW}$	$+ 0.01/100*6.252\text{W})$
	$= \pm(138\text{uW}$	$+ 13.8\text{uW}$	$+ 625.2\text{uW})$
	$= \underline{\underline{\pm 777\text{uW}}}$		

7.3 Example of an error calculation: LMG500 with HST3

In this example an error calculation is shown with the LMG500 and HST3 measuring the loss power of a 3000V / 10A / 60Hz, pure sinewave voltage and current / PF=0.3 device under test

- **HST high voltage divider**

HST3 scale = 1000:1

HST3 tolerance: $\pm 0.05\%$ / $\pm 0.06^\circ$ @ 45 .. 65Hz

$\Delta\phi_{\text{HST3}} = \pm 0.06^\circ / 360^\circ * 2 * \pi = \pm 0.001047197551 \text{ rad}$

- **Voltage measurement**

$U_{\text{eff}} = 3000\text{V} / 60\text{Hz}$

LMG500 U_{scale} = 1000

LMG500 U_{range} = (3V / 6V_{pk}) = 3000V / 6000V_{pk}

LMG500 U measuring accuracy: $\pm(0.01\%$ of measuring value + 0.02% of measuring range)

- **Current measurement**

$I_{\text{eff}} = 10\text{A} / 60\text{Hz}$

LMG500 I_{range} = 10A / 30A_{pk}, direct current input

LMG500 I measuring accuracy: $\pm(0.01\%$ of measuring value + 0.02% of measuring range)

- **Power measurement**

PF = 0.3, pure sinewave voltage and current -> $\phi = \arccos(\text{PF})$

f = 60Hz

S = $U_{\text{eff}} * I_{\text{eff}} = 30\text{kVA}$

P = $U_{\text{eff}} * I_{\text{eff}} * \text{PF} = 9\text{kW}$

LMG500 P_{range} = U_{range} * I_{range} = 6000V * 30A = 180kW

LMG500 P measuring accuracy: $\pm(0.015\%$ of measuring value + 0.01% of measuring range)

Tolerance of voltage and power measurement

$\Delta U_{\text{LMG500}} = \pm(0.01/100 * 3000\text{V} + 0.02/100 * 6000\text{V}) = \pm(0.3\text{V} + 1.2\text{V}) = \pm 1.5\text{V}$

$\Delta U_{\text{HST3}} = \pm(3000\text{V} * 0.05/100) = \pm 1.5\text{V}$

$\Delta U_{\text{total}} = \pm(\Delta U_{\text{LMG500}} + \Delta U_{\text{HST3}}) = \pm 3\text{V}$

$\Delta P_{\text{LMG500}} = \pm(0.015/100 * P + 0.01/100 * P_{\text{range}}) = \pm(1.35\text{W} + 18\text{W}) = \pm 19.35\text{W}$

with $P = U * I * \cos(\phi)$

$\Delta P_{\text{HST3}} = \pm(|dP/dU * \Delta U_{\text{HST3}}| + |dP/dI * \Delta I_{\text{HST3}}| + |dP/d\phi * \Delta\phi_{\text{HST3}}|)$

with $\Delta I_{\text{HST3}} = 0$ (current measurement has no influence on voltage measurement)

$\Delta P_{\text{HST3}} = \pm(|I * \cos(\phi) * \Delta U_{\text{HST3}}| + |U * I * \sin(\phi) * \Delta\phi_{\text{HST3}}|)$

$\Delta P_{\text{HST3}} = \pm(10\text{A} * 0.3 * 1.5\text{V} + 3000 * 10 * \sin(\arccos(0.3)) * 0.001047197551) = \pm 34.47\text{W}$

$\Delta P_{\text{total}} = \Delta P_{\text{LMG500}} + \Delta P_{\text{HST3}} = \pm 53.82\text{W}$