

LMG600 Series Precision Power Analyzer

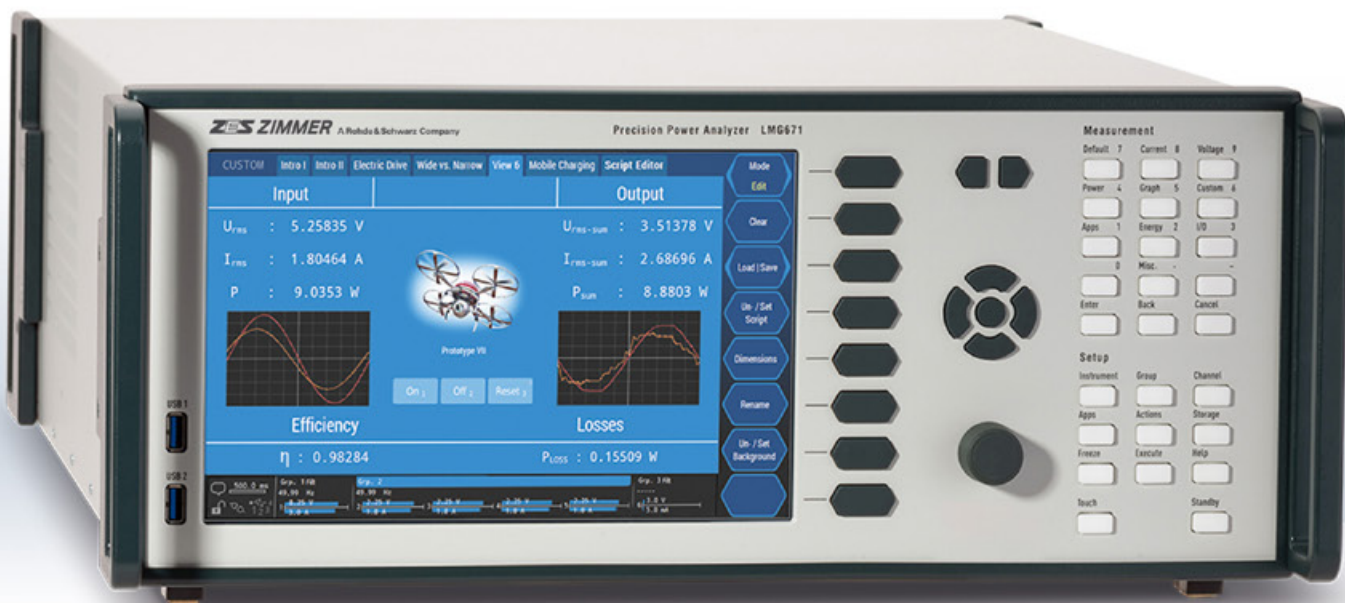

**Getting precise results does
not have to be complicated**

LMG600 – The Advantages of Our Power Analyzer Series

Features	Harmonics	<ul style="list-style-type: none"> • Harmonics and interharmonics up to the 2000th order, in compliance with EN61000-4-7
	Script Editor	<ul style="list-style-type: none"> • Flexible scripting tool for special applications • Convenient calculation of all derived variables in the power analyzer
	Custom Menu	<ul style="list-style-type: none"> • Creation of customer specific application oriented menus
	Simultaneity	<ul style="list-style-type: none"> • Simultaneous measurement of I, U and P-variables and harmonics • Presentation in tabular or graphical form
	Flexible Filters	<ul style="list-style-type: none"> • Signal filters freely configurable by frequency, type and characteristics
	Plug 'n' Measure	<ul style="list-style-type: none"> • Connected current transducers are automatically configured and supplied with power • Convenient commissioning with zero risk of misconfiguration
	Synchronization	<ul style="list-style-type: none"> • Synchronize on different frequency sources
	Flicker	<ul style="list-style-type: none"> • Interactions between grid and loads according to EN61000-4-15
	Sample Values	<ul style="list-style-type: none"> • Direct access to high-resolution sample values and harmonics via interfaces
	Event Triggering	<ul style="list-style-type: none"> • Event based recording of sample values
Measurement Channels	Smart Vision	<ul style="list-style-type: none"> • Smart add-on functions for convenient evaluation of measurements
	DualPath	<ul style="list-style-type: none"> • Narrowband-, wideband RMS values and harmonics in a single measurement, simultaneously and free of aliasing
	Resolution	<ul style="list-style-type: none"> • Calculation of RMS values with a minimum cycle time of 10 ms
	Accuracy	<ul style="list-style-type: none"> • Extremely high measurement accuracy of 0.015 % of the measured value + 0.01 % of the measuring range limit
	Dynamic Range	<ul style="list-style-type: none"> • Full dynamic range continuously available from 500 μA to 32 A and 3 mV to 1000 V • Power measurement from standby to full load (max. 32 A) possible without mechanical changes
	Bandwidth	<ul style="list-style-type: none"> • Analog frequency range from DC up to 10 MHz • Analysis of 1000 harmonics in the GUI and 2000 via interface
	Continuity	<ul style="list-style-type: none"> • Gapless sampling at 18 bit A/D converter resolution and a cycle time of 10 ms • No discontinuities in recorded measurements and complete capturing of all relevant events
	U-I-Synchronicity	<ul style="list-style-type: none"> • Time offset between current and voltage input adjustable in steps < 3 ns • Very precise measurements at small power factors (PF) and/or high frequencies
	Immunity	<ul style="list-style-type: none"> • Reliable even in areas with difficult electromagnetic conditions
	Ground Capacitance	<ul style="list-style-type: none"> • Particularly low earth capacitance of < 90 pF avoids interference by leakage currents
GUI	Touch Screen	<ul style="list-style-type: none"> • Flat operating hierachy for rapid access to all important menu items
	Remote Control	<ul style="list-style-type: none"> • Real-time display of all device functions, remote operation and data visualization • No rethinking required, thanks to the new unified GUI
Storage & Periphery	CAN bus	<ul style="list-style-type: none"> • Simple provision of measured values via bi-directional CAN bus
	Memory	<ul style="list-style-type: none"> • Internal storage even of long-term measurements with the shortest cycle time, thanks to high-capacity mass-storage device
	Interfaces	<ul style="list-style-type: none"> • Excellent connectivity provided by USB 3.0, Gigabit Ethernet, RS-232, DVI
Misc.	Calibration	<ul style="list-style-type: none"> • 12-month calibration interval guarantees low maintenance costs and optimum device availability • Includes calibration certificate upon delivery, free of charge
	Warranty	<ul style="list-style-type: none"> • 12 months warranty

LMG671 and LMG641 – Quick overview

Pushing the limits

- ✓ Measuring standby currents in the μA range and up to 32 A
- ✓ Market-leading analog bandwidth of 10 MHz
- ✓ Unique DualPath architecture eliminates aliasing dilemma
- ✓ Best-in-class accuracy

Easy data exchange

- ✓ Collect data from any analog or digital sensor
- ✓ Plug into CAN bus to blend into automotive environment
- ✓ Continuously stream sample values for advanced post-processing
- ✓ Run our sophisticated analysis suite on captured data



Fits to your task

- ✓ Configure the number and kind of your power channels for the best price and performance
- ✓ Sync to different frequencies on each channel group
- ✓ Focus on the relevant signal content with highly versatile filters
- ✓ Customize your analysis in content and appearance

Barrier-free measurements

- ✓ Quickly familiarize yourself with our touchscreen GUI
- ✓ Adapt it to your own needs with a few clicks
- ✓ Enhance your screenshots with on-screen comments and sketches
- ✓ Add sensors using Plug'n'Measure

LMG671-ATE – Optimized for rack-mounting

Power analyzers can contribute to many stages of the product lifecycle, from R&D to end-of-line testing. The requirements for accuracy, bandwidth and range of functions vary with location and purpose. Using the same measurement technology during different stages of product maturity allows to avoid deviations in results by providing a common reference. Commonality in measurement hardware is very desirable, but

when it comes to operation, the desktop instrument of an R&D engineer and the rack-mounted unit in an automated test system could not be more different. Manual operation via front panel vs. remote control. On-screen evaluation vs. high-speed streaming of sample data to a central repository. Local operation is not only unnecessary, it is often undesirable and should be blocked to prevent unauthorized access or accidental

interference by untrained personnel.

Therefore, in most cases in an automated test environment a front panel GUI is redundant. Eliminating key panel and screen increases application-specific usability and lowers costs. In these cases, the LMG-ATE with its unique combination of time-proven measurement hardware and specific operation is the instrument of choice.



LMG671-ATE Features

- ✓ Optimized for rack-mounting
- ✓ Remote operation via Gbit-Ethernet or CAN (optional)
- ✓ Automatic zero-adjustment
- ✓ Incl. video interface for convenient configuration
- ✓ Complete configuration can be saved and retrieved via USB flash drive
- ✓ Suitable for all channel types (A, B, C, S)

LMG611 – Compact Single-Channel Power Analyzer

The LMG611 is a high-precision single-channel power analyzer in a compact desktop format and is considered one of the most accurate instruments in its class. It offers exceptional reliability, first-class accuracy, and an exceptionally wide frequency range—ideal conditions for precise measurement results. With a measurement accuracy of 0.015% of the measured value plus 0.01% of the range, it covers AC ranges from

5mA to 32A and from 3V to 1000V. Power analyses are possible from standby to full-load operation without any modifications. Thanks to a bandwidth from DC to 10 MHz, full-resolution sampling up to 18 bits, and minimum cycle times of 10 ms, the device delivers fast and precise results. The innovative DualPath architecture enables the simultaneous measurement of narrowband and wideband values as

well as the analysis of harmonics up to the 2000th order. This is complemented by flexible filters, scripting functions, and comprehensive visualizations. The device is conveniently operable via touchscreen, while numerous interfaces and integrated memory ensure convenient data acquisition and further processing.



LMG611 Features

- ✓ Outstanding accuracy of 0.015% of measured value + 0.01% of range
- ✓ Full dynamic range 500µA-32A, 300mV-1000V per channel available in single instrument
- ✓ Analog bandwidth DC up to 10 MHz
- ✓ Compact Desktop Device

Hardware and Basics – What is where

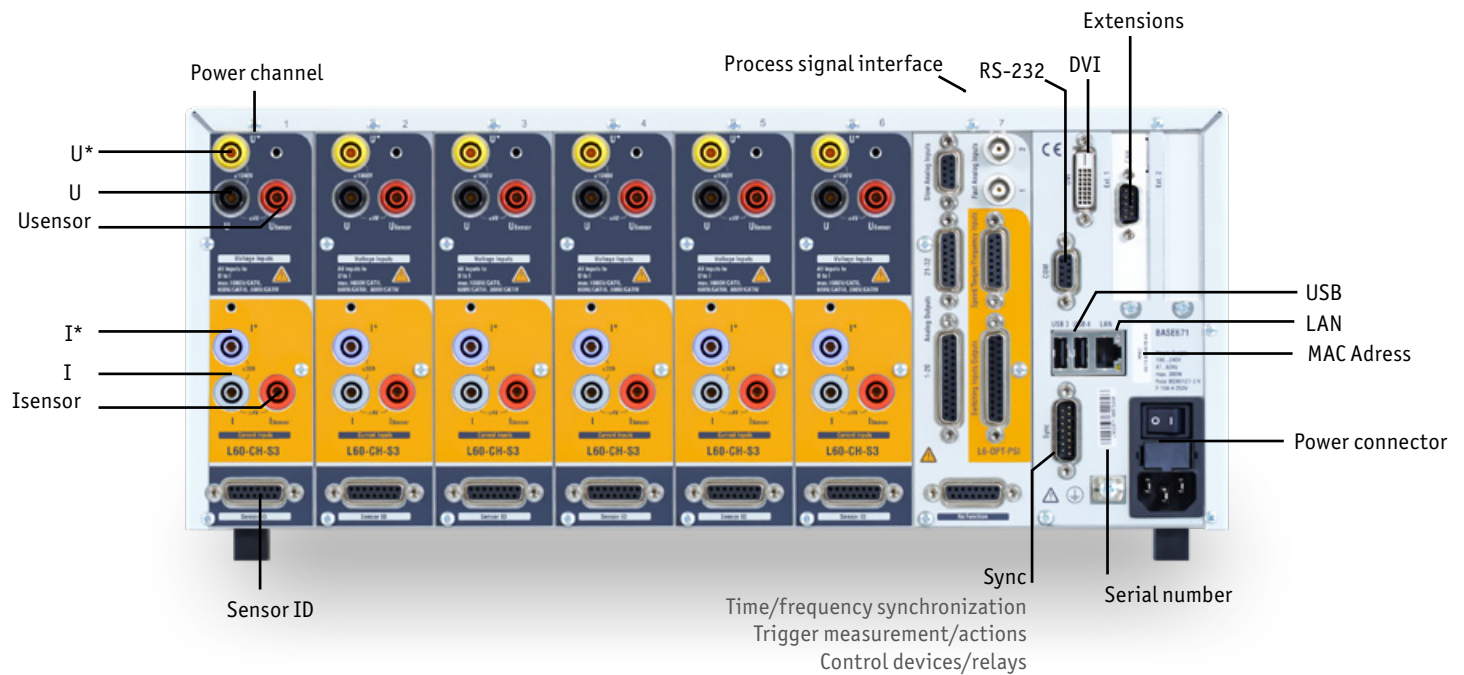
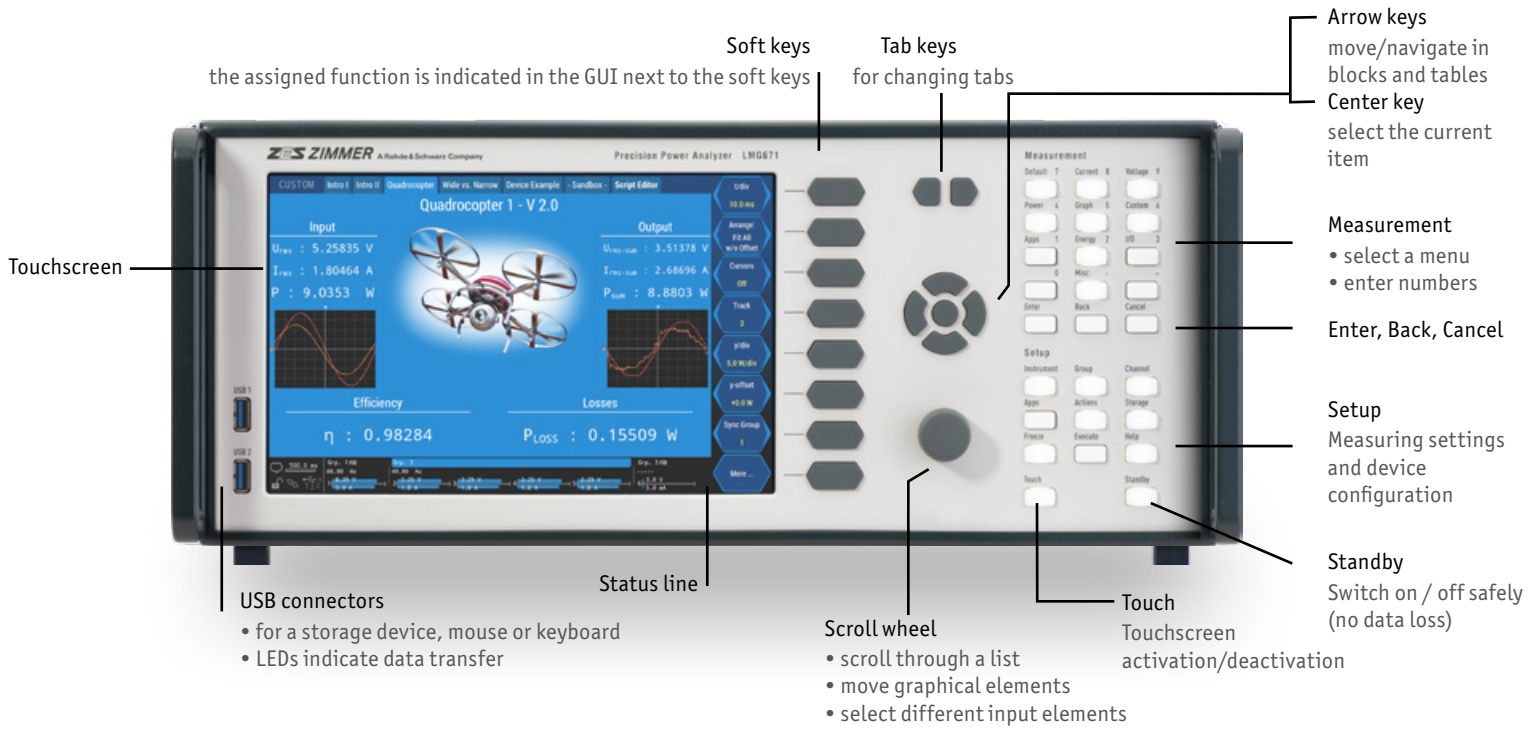

LMG600 Power Channels – A, B, C or S?

Power analyzers are available in different accuracy classes, to allow the user to choose the right tool for the job at hand. After all, not all applications require maximum precision; often lower resolution and frequency range are sufficient. Unfortunately, not all measuring applications exhibit this distinction. It is very

well possible, for instance, to have need for different frequency ranges and accuracy levels at different points in the same measurement configuration. This is why the LMG600 offers four different channel types, which can be combined in the same chassis without problems to ensure that you always have a measuring device tailored to your needs

for your particular application. No need to accept trade-offs in accuracy or take a sledgehammer to crack a nut, if a lower priced solution could have served your purposes equally well.

Best in class: The new S-Channel



- ✓ Superior AC & DC accuracy & stability
- ✓ Dedicated AC/DC ranges
- ✓ Automatic zero-adjustment
- ✓ Up to 600 VAC, measurement category CAT III
- ✓ Up to 1000 VDC, measurement category CAT II

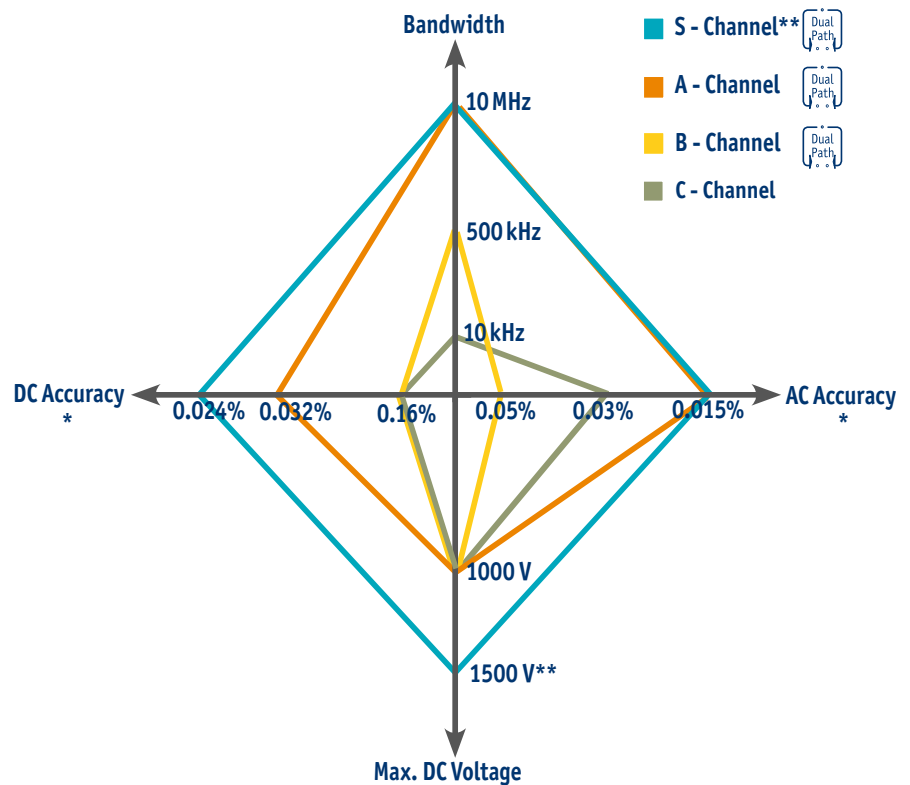

* ± (% of measured value)

** with additional adapter L60-CH-S-VRE

S/A - Channel

- ✓ High accuracy
- ✓ High bandwidth
- ✓ High frequency ferrite core losses
- ✓ High frequency bearing currents
- ✓ Inductive heating
- ✓ Ultrasonics
- ✓ Ballasts



C - Channel

- ✓ Precise measurements at 50/60 Hz
- ✓ Standby power measurements
- ✓ Core losses
- ✓ Impedance measurements on transformers
- ✓ Quality grid
- ✓ Power transformers
- ✓ Domestic appliances

B - Channel

- ✓ Cost-effective
- ✓ Power tools
- ✓ Universal laboratory tools



The right channel combination for every application

The LMG671 and LMG671-ATE devices can be equipped with 1 to 7 power measuring channels (alternatively 6 measuring channels and Process-Signal-Interface). The retrofitting of channels is available. Many applications need auxiliary values that have to be provided. Examples are values from

temperature sensors, speed or torque sensors, auxiliary voltages, or alarm signals. Such values can be handled by the Process-Signal-Interface (PSI). This interface has several inputs and outputs (see below). Note: The PSI* occupies a power channel slot and can be combined with a vari-

ety of power channels to suit your application.

For example:

- 6 S-Channels + 1 PSI
- 3 S-Channels + 3 A-Channels + 1 PSI
- 3 S-Channels + 2 A-Channels + 1 B-Channel + 1 PSI

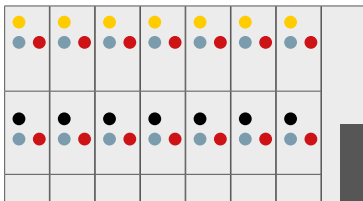

7 power measuring channels
Power measurements on inverter / motor combination with DC

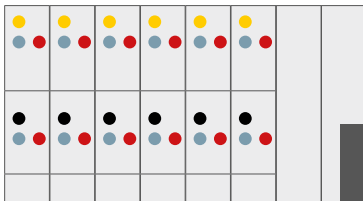

6 power measuring channels
Power measurements on inverter / motor combination, 3-phase

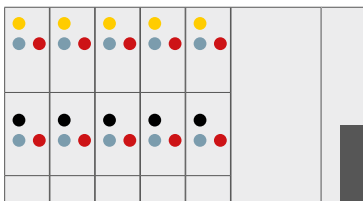

5 power measuring channels
Inverter with DC link
1-phase Input, 3-phase Output

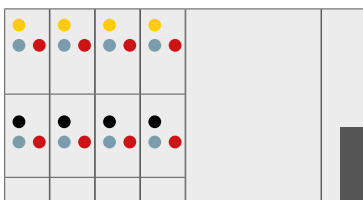

4 power measuring channels
Inverter measurements
1-phase Input, 3-phase Output

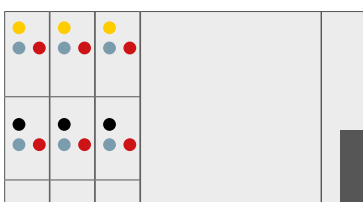

3 power measuring channels
power measurement of 3-phase motors

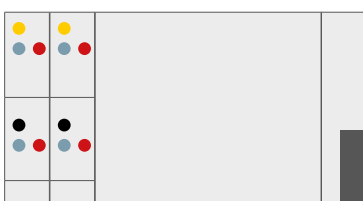

2 power measuring channels
Efficiency measurement of power supplies

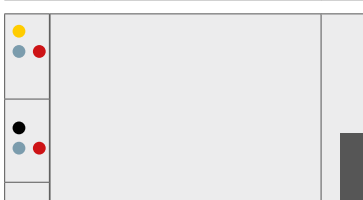

1 power measuring channel
Measuring of core losses

Flexible Process-Signal-Interface



- ✓ 8 digital inputs
- ✓ 8 digital outputs
- ✓ 2 fast analog inputs (150 kS/s, 15 kHz bandwidth)
- ✓ 8 slow analog inputs (DC)
- ✓ 32 analog outputs
- ✓ 2 frequency inputs (frequency, orientation, position; DTL, HTL, or differential)

*PSI is only available for LMG671, LMG-ATE, and LMG641.

Key features at a glance

Measuring in two bandwidths at the same time, thanks to DualPath - no compromises, no doubts

On conventional power analyzers, a signal undergoes analog conditioning, followed by optional anti-aliasing filters, before being fed into an A/D converter. The resulting signal can afterwards be used for the calculation of cycle-based RMS values. Alternatively it can serve as the base for an FFT or further digital filtering. Due to the limitation of using a single A/D converter, there are inherently some downsides to be factored

in with conventional devices. If measurements are carried out with filters active, in order to avoid aliasing with FFTs, then the wideband values are lost. With the filters switched off, strictly speaking, FFTs should not be used. If, in spite of this, FFTs are used without an anti-aliasing filter for measurements across the full frequency range, then the quality of the calculated values is questionable. An aliasing error of 50%, for

instance, is easily detected, however a deviation of 0.5% could go unnoticed. Ultimately, when you alternate filtered and non-filtered measurements, the validity of the results is equally in question, as this involves the assumption that the signal does not change over time, which is in practice hardly ever the case. In addition, this procedure is especially time consuming.

LMG600



- ✓ Fast results
- ✓ Complete broadband values
- ✓ Correct FFT
- ✓ Precise results

Conventional analyzers

- ⊖ Aliasing risk
- ⊖ Loss of broadband values
- ⊖ Waiving of FFT
- ⊖ Doubtful repeatability
- ⊖ Lengthy measurements

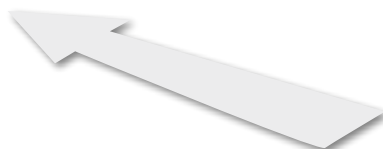

In the end, all of the measurement methods presented above are merely unsatisfactory compromises. This is why ZES ZIMMER has fundamentally redesigned signal processing and developed the DualPath architecture. The analog side is the same as in conventional measuring devices, however the subsequent digital processing has been revolutionized. The LMG600 is the first power analyzer to have two A/D converters in two independent signal paths for each current and voltage channel. One, for the filterless measurement of the wideband signal, and another, for the narrowband signal at the output of the anti-aliasing filter. The parallel processing of the digitized sample values gives the user access to both measurements of the same signal, without risking aliasing effects. This unique procedure avoids all of the downsides of previous approaches and guarantees the most precise result in the shortest time possible.

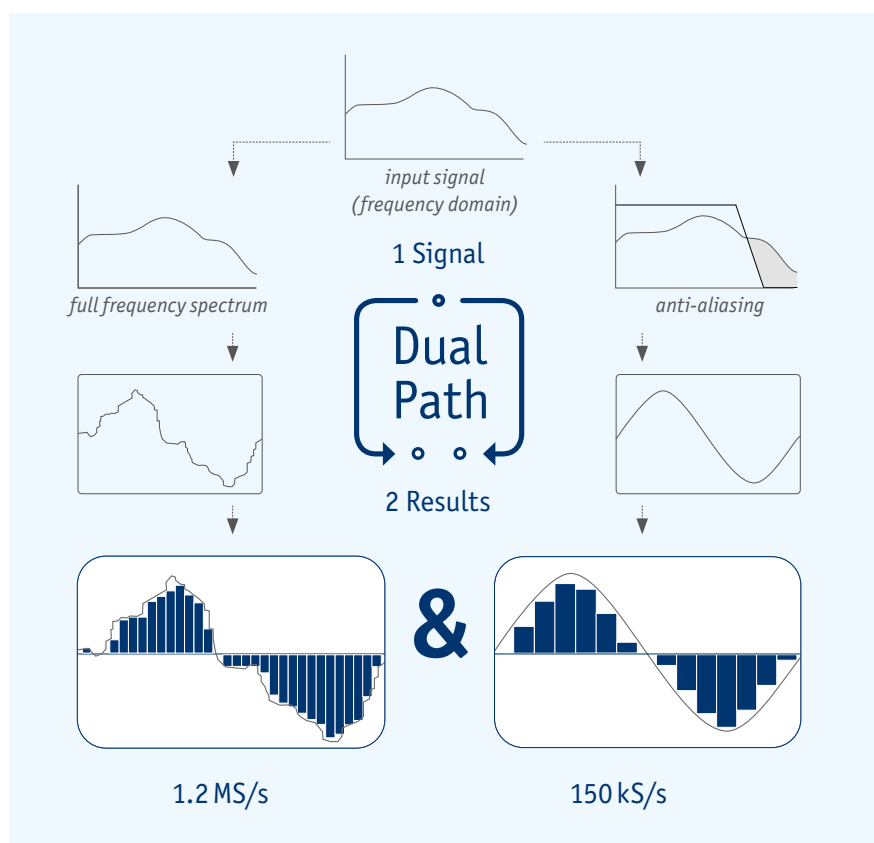

Gapless/zero-blind measurement

In the course of stricter monitoring of the consumption and efficiency of electrical devices, new standards and procedures are continuously being introduced (e.g. SPECpower_ssj2008, IEC 62301, EN 50564), in order to enable an impartial comparison of products from different manufacturers. Be it an office computer, server or household appliance, the same principle applies:

the procedure always requires long term analysis of the power consumption, taking into account all relevant operating conditions. The differences between minimum load - e.g. in standby - and full load can be of a significant magnitude, which makes precise measurement very challenging (see also application report no. 102 „[Measurement of standby power and energy](#)

[efficiency](#)“ at www.zes.com). Some of the measurements required must be performed over several hours, yet without gaps. By selecting a sufficiently high measurement range, changing ranges and the inevitably associated losses in data can be avoided. The high basic accuracy of the LMG600 ensures precise measurement results, even near the lower limit of a range.

Precise measurements thanks to minimal delay differences

The fast-switching semiconductors used in modern frequency converters to improve efficiency produce extremely steep voltage edges. The resulting capacitive currents put strain on the bearings and the insulation of the motors – this can lead to premature failure.

Motor filters (e.g. dU/dt filters) attenuate the steep voltage gradient, although they generate power losses themselves due to the transient oscillation with the filter's own frequencies (typically > 100 kHz).

The broad frequency range and the minimal delay between current and voltage on the LMG600 allow extremely precise power loss measurements on the filters at these frequencies, including longitudinal measurements at low power factors. This also applies to power measurements with high frequency ranges of up to 10 MHz, which require the current and voltage channels to be designed for the smallest delay differences. On the LMG600 the offset is less than 3 ns, corresponding to a phase error < 1 μ rad at

50 Hz. This makes the devices best suited to measure the power losses at low phase angles for transformers, chokes, capacitors and ultrasonic generators. No additional options or adjustments are required; the LMG600 is already fully capable of this measurement task with the standard factory settings. Usually current and voltage transducers are used for measurements on high-power circuits. The phase angle of these transducers can be corrected to improve measurement accuracy.

Range extension with sensors? Plug 'n' Measure!

Although the LMG600 offers unmatched dynamic range, both for voltage and current, there are always applications with extraordinary requirements in terms of measurement ranges. Whether you are dealing with currents of several hundred amps or voltages of several kilovolts, ZES ZIMMER has the right solution at the ready. We offer a wide range of current and voltage sensors, which work perfectly in unison with the LMG600 precision power analyzer and extend the measurement ranges of the device by the required amount. The sensors of our Plug 'n' Measure series are equipped with a bus system, which enables automatic configura-

tion of the LMG600. This allows for all of the important parameters, such as the precise scaling factor, the delay compensation variable, the last calibration date, and the sensor type, to be read and used automatically by the power analyzer. Moreover, the sensors are actively supplied with power by the LMG600, separate power supplies are no longer required.

With Plug 'n' Measure there is no need for fine tuning by the user to improve the results. There is no difference between direct and sensor-supported measurements. Of course, other commercially available sensors can also be used with the LMG600.



Sensor Type PCT

Powerful interfaces

In test bench environments, the power analyzer often must share its measurements with other existing computer and software environments.

As the high sampling rate of the LMG600 inevitably creates a large amount of data, we equipped it with a powerful Gigabit ethernet LAN interface to avoid bottlenecks. Even high-resolution measurements of all important parameters, such as current, voltage, active power, etc. over a period of several minutes or even hours can be rapidly transferred to a connected computer. In automotive environments CAN bus is widely used. By choosing the LMG600's CAN bus option, measurements can directly be shared over CAN, and the LMG600 can in turn act on data received over CAN (details on p.14).

Other interfaces are useful to connect peripheral devices for input or visual output. A USB 3.0 slot is available, and the LMG600 can also be equipped with a DVI interface to connect an external monitor or projector. Two more slots can be retrofitted for future interface standards.

The integrated sync interface allows to precisely synchronize multiple LMG600 with one another. It creates a common time base for measurements involving multiple LMG600 on the same system, or the mutual connection and control of an LMG600 by oscilloscopes or waveform generators.

The internal SSD of the LMG600 can store measured values, settings, user-defined measurement variables, or graphs for later use, even without having a PC connected. The firmware of the LMG600 can be quickly and easily updated via USB.

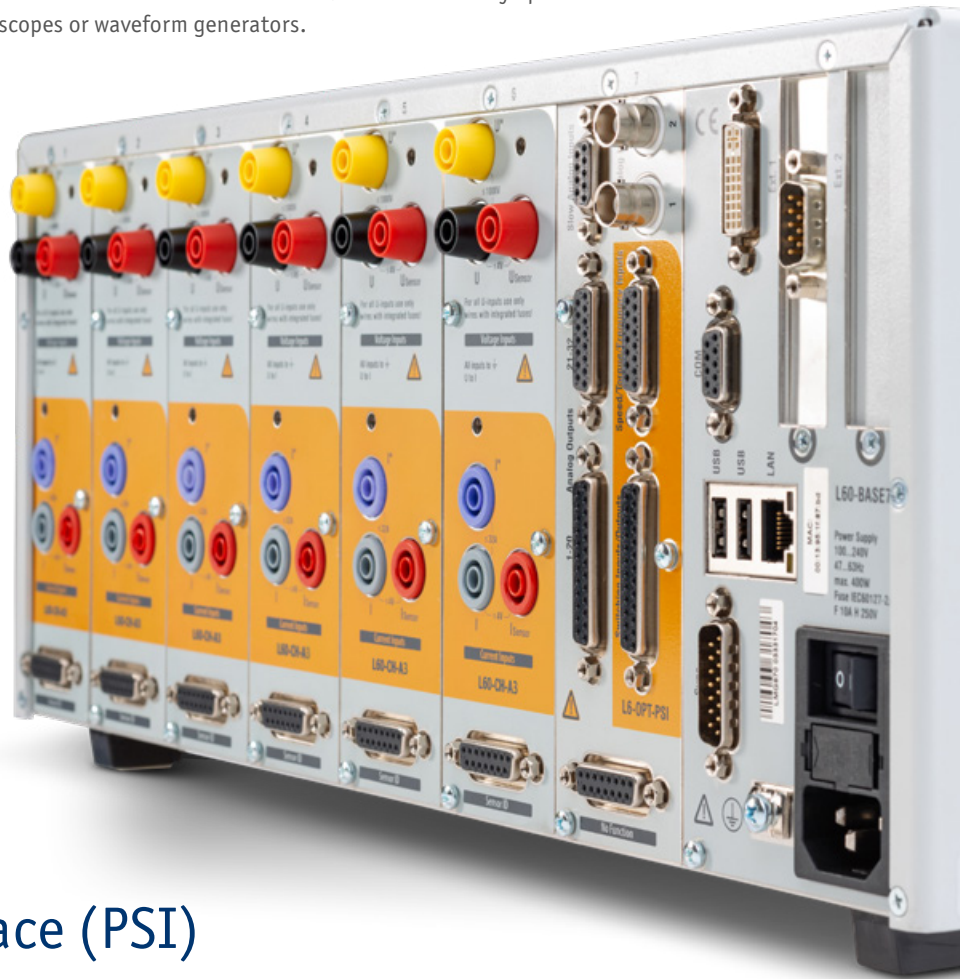

Process signal interface (PSI)

In-/Outputs

- ✓ 2 fast, synchronized analog inputs (ca. 150kS/s)
- ✓ 8 analog inputs
- ✓ 8 switching inputs (ca. 150kS/s)
- ✓ 2 torque-/speed-/frequency inputs
- ✓ 32 analog outputs
- ✓ 8 switching outputs

It is often necessary to take further measurements in addition to electrical parameters to be able to make a meaningful overall statement on the performance and efficiency of the device being tested. Hence, it is vital to be able to perfectly synchronize these measured values with the RMS values calculated by the LMG600, in order to establish reliable timing between electrical and mechanical events. A typical application is the analysis of electrical drive systems, where torque and speed must be measured and reconciled with the

electrical parameters. Conversely, it may also be necessary for the power analyzer to output results as analog signals for further processing, or to trigger switching operations depending on measured variables or derived values. In order to be equipped for all of these potential requirements, the LMG600 offers a multitude of different input/output features for analog and digital signals.

Star-to-delta conversion

In three-phase three-wire systems, only the line-to-line voltages U_{12} , U_{23} , U_{31} and the line currents I_1 , I_2 , I_3 are accessible for measurement. With the star-to-delta conversion option, the line-to-line voltages can be converted to non-accessible phase voltages and the related active power can be determined. Likewise the line currents can be converted into the phase currents. From these calculated values it is possible to derive all other variables, such as

harmonics. Distortions and imbalances of the grid or consumers are properly taken into account. This makes the use of an external, artificial neutral point superfluous;

although one could use such at any time, provided that the associated disadvantages (e.g. increased power losses) are taken into account.

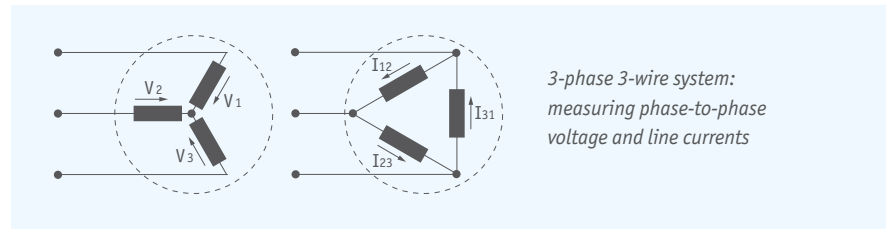

Easy to use – with or without touchscreen

To ensure that the LMG600 can be used in all conditions, particular attention has been paid to universal usability. All display modes and setting options can be operated both by the touchscreen or the keypad, without exception. The optimized design consistently links the keypad to the associated views and setting options on the screen. To use the instrument effectively requires almost no familiarization. The graphical user interface directs the user without detours to the required values. Be it RMS of voltage or current, associated harmonics or cumulative

values, these are usually only a single press of a button away. In addition, user-defined views allow to group individually measured values, so that all the parameters are always available at a glance. This ergonomic way of operation and the associated time savings contribute directly to the productive use of the LMG600. The eight context-specific double softkeys to the right of the display, whose function always corresponds to their on-screen counterparts on the right-hand side, are especially important for ease-of-use. One can determine the function as-



signed to a given softkey at a glance. The double softkey design enables the respective parameter to be rapidly configurable; switching through views that are not relevant is no longer necessary. Should there be questions about function and control while operating the device, the relevant sections of the manual can be displayed at any time.



Simultaneous measurement of narrowband and wideband values



Superimposed help text from manual

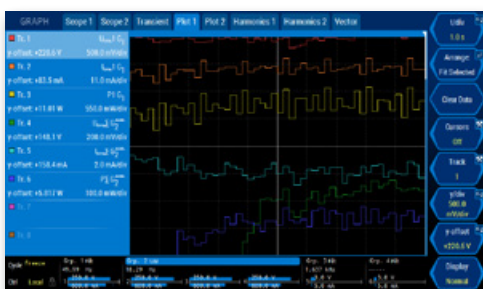

Plot of measured RMS values



Display of sampling values of 16 signals in two scopes

Everything important just a click away

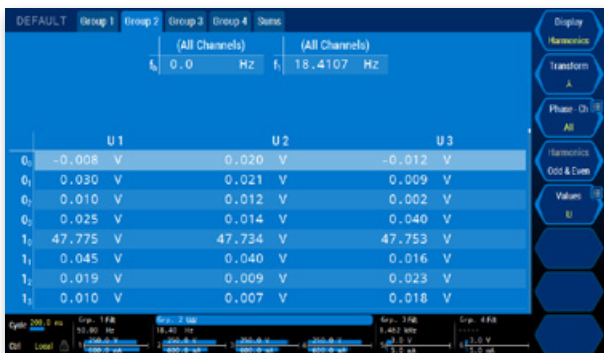

Click on softkey <Display> to toggle between RMS values and harmonics

Click on softkey <Phase-Ch> to display measured values for all channels or linked values in a group



Click on Cycle to set the duration and the reference of the measurement cycle



Click on the group to change the signal, harmonics and synchronization settings

Click on the level indicator to configure the channel-specific measurement ranges and sensor settings

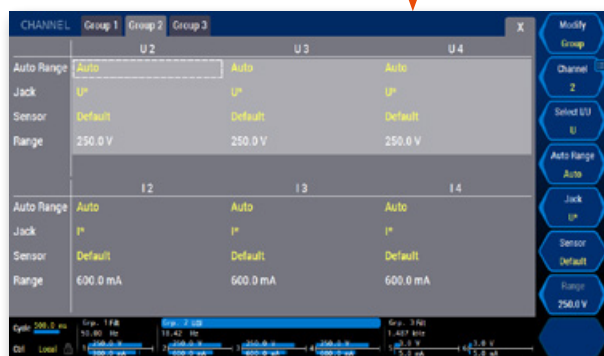

Capturing important events on scope

Steady-state measurements are making up a considerable portion of power analyzers' everyday use scenarios. Still, it is often the unpredictable events that give design engineers a headache. Reliable detection of transient conditions imposes heavy demands on the instruments used.

Whenever supreme accuracy, low measurement ranges, direct current measurement and robust electrical isolation are required, oscilloscopes and transient recorders have to cede to power analyzers.

ZES ZIMMER's LMG600 series power analyzers can be equipped with the Event Trigger software option (L6-OPT-EVT) to monitor voltage and current signals for unique conditions. Those conditions can be characterized by upper and lower bounds of the sample values, which can also be combined to define signal windows for triggering.

After trigger conditions have been set, ZES ZIMMER's Trigger View offers a convenient way to verify the correctness of the settings. Trigger View visualizes the effects of settings like sync filters and level or hysteresis

and displays the resulting trigger signal.

Once the defined conditions are met for the minimum duration chosen by the customer, recording is activated. The length of the recording can be chosen by the user, with 16 tracks at 16MS (LMG670: 4MS) each available for storage. The recorded samples are available graphically on the LMG600's scope in a separate tab, or numerically via the data interfaces for further analysis. Using the event trigger function has no impact on cycle based power measurements carried out in parallel on the same channel.

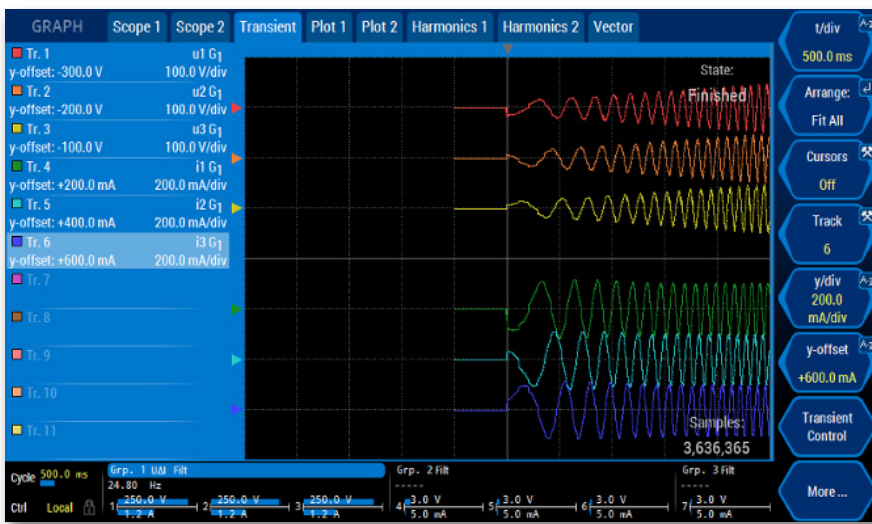

Screenshot of Event Trigger option with up to 16 million samples. The Scope View offers a quick and convenient way to visualize signals in the time domain. The viewer for the Event Trigger allows you to display the behavior of voltage, current, power or other variables in 16 tracks from different channels in graphical form and with a variable time base. Cursors can be used to mark segments or measure differences of time and amplitude between two points. The reciprocal value of the time difference (i.e. frequency) is also provided. Further analysis of the samples can be performed on PC using the LMG Sample Vision software.

Synchronization - no need to stop at 7 channels

The LMG600 series already offers the highest channel count per chassis in the power analyzer market, yet there are applications which require 8 or more points of power measurement. The solution is simple: combine multiple LMG600 chassis' to create a virtual power analyzer with more channels. All you need to do is to connect the individual units via sync cable, and they will automatically synchronize:

- ✓ cycle timing
- ✓ system time
- ✓ transient trigger events
- ✓ state of energy integration

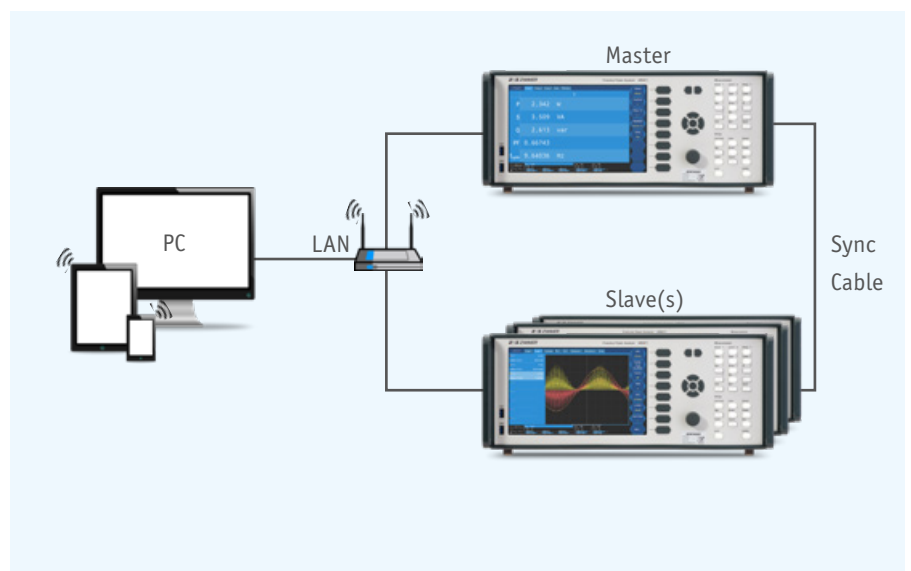

Bi-directional CAN interface – remote control via CAN

In many test setups involving power analysis, the majority of the data to be evaluated will come from the power analyzer itself. The automotive environment, however, typically differs a lot. Modern cars can be equipped with hundreds of electronic control units (ECUs) and sensors of different kinds. Within the sea of data points these devices generate, voltage, current and power values are just a minor subset. Nevertheless, this subset needs to be integrated with the remainder of the data for the test engineers to benefit from it.

While ECU and sensor data typically get exchanged over the CAN bus, traditional power analyzers communicate via GPIB or Ethernet. Thus, it is up to the test engineers to reconcile data from both sources and to put it in a common format in order to correlate it. This is no mean feat, as there is usually no common time basis between the CAN data and the values provided by the power analyzer, and matching electrical parameters to other sensor data is very challenging. In any case, there is a lot of manual intervention involved, and the procedure is cumbersome, lengthy and error-prone.

The LMG600 is the only dedicated power analyzer in the world that is able to share up to 128 values and variables over CAN bus. This unique capability helps to bridge the gap between the automotive industry's most popular field bus and traditional test & measurement equipment. Test engineers can now read voltage, current, power etc. the same way they read speed, torque, temperature and other variables: by gathering data from sources on the CAN bus. No sep-

arate treatment, no extra work, no distinct data repositories. The necessary time to integrate power measurements into the overall test environment shrinks drastically. The need for additional middleware is eliminated, costs are contained at the necessary minimum. With the latest firm-

This feature offers a convenient way to e.g. trigger data logging based on environmental conditions or change measuring ranges according to the state of the unit under test. Imagine you would like to initiate logging data once a critical temperature threshold is exceeded at a certain location. To imple-

Slot	CAN Id	EFF Bit	Measurand	Status
1	15	Off	P1 G1	ON
2	16	On	U _{rms} 1 G1	ON
3	17	Off	I _{rms} 1 G1	ON
4	18	On	Ih1 G1 (1)	ON
5	19	Off	EP1 G1	ON
6	20	Off	PF1 G1	ON
7	21	Off	PSIM _{TORQUE}	ON
8	22	On	PSIM _{SPEED}	ON
9	23	Off	Transient 0, (1)	ON

Define the measurands sent to CAN bus

LMG triggers on data or commands from CAN bus and executes actions (e.g. starts a log)



LMG sends measurands to CAN bus



ware release, the LMG600 can also read information sent over the CAN bus and carry out a number of predefined actions based on its content. That is, the CAN bus interface of the power analyzer has become bi-directional, changing it from a purely passive sensor to a remote-controllable analysis tool.

ment this procedure you simply would have the LMG600 read the information sent by the respective temperature sensor over CAN and set a trigger condition accordingly. Once the temperature has risen above the limit, recording starts automatically. Likewise, switching an electrical engine off via CAN could simultaneously trigger a range change in the power analyzer, avoiding the otherwise necessary settling period of the auto-ranging mechanism. The LMG600 allows to define up to 128 trigger conditions to cover automation of even the most sophisticated measurement and recording tasks.

Id	EFF	Offset	Bit Length	Op. Type	Condition	Ref. Value	State
10	Off	0	8	INTEGER	GREATER	28	ON
1	Action : logonce						
11	Off	0	8	INTEGER	GREATER	28	ON
2	Action : logonce						
0	On	0	0	INTEGER	NEQUAL	0	OFF
3	Action :						
0	Off	0	0	INTEGER	NEQUAL	0	OFF

Define actions for the LMG for incoming data of the CAN bus

Testing without disruption – five in one

In a typical test scenario, the way from raw signals to the final pass/fail indication is a long and winding path stretching over five distinct phases. Computing RMS power is only one piece of the puzzle, and data from other sources might need to be integrated into the calculations. This can lead to a complex assortment of data sources and processing tools with many handover points. The discontinuities in the flow of data may require manual intervention, which demands time and effort and increases the risk of introducing errors.

The LMG671 is designed to combine all five phases of testing into a single instrument, thus eliminating unnecessary complexity, streamlining the testing process, making test engineers' life easier and keeping cost down.

1. **Signal acquisition:** the LMG671 goes beyond voltage and power. The versatile Process Signal Interface (PSI) can read virtually any analog or digital signal source, thus allowing e.g. temperature, pressure, speed, torque and other data to be collected together with voltage and current. No need to reconcile data points from different sources later on, no issues with inconsistent timestamps between variables.

2. **Timing control:** for the test results to be meaningful, the DUT needs to be observed in specific, predefined modes of operation. The LMG671 can control beginning and end of the measurements via the versatile Event Trigger option. In addition, it can react to external trigger inputs or CANbus commands to start recording data. The LMG671 can also control external devices via a number of analog and digital outputs in the optional PSI.

3. **Integration:** to calculate RMS voltage, current and power as well as harmonic values, the samples need to be summed over entire signal periods – this is the traditional domain of power analysis. (Outsourcing the calculation to PC environments already at this step renders the

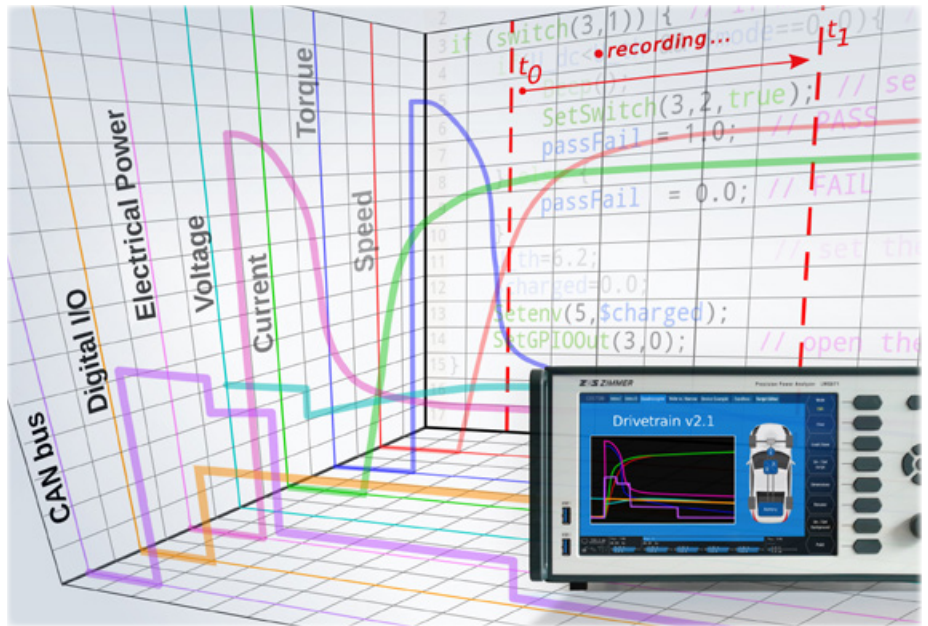

integrity of RMS values and harmonics vulnerable and makes calibration of the setup rather difficult.)

4. **Derivation:** in many applications, the measurement of electrical quantities is just a means to an end and not the final goal. An illustrative example is the qualification of inductive components: measuring voltage and current ultimately yields core losses and the peak values of magnetic field strength and flux density. Rather than exporting electric measurements to 3rd party applications for the calculation of the desired results, the LMG671 offers a powerful built-in programming language with a vast number of mathematical functions to carry out all required calculations in one fell swoop. No handover, no disruptions, no risk of additional errors.

5. **Pass/fail decision:** In case the DUT is tested against defined standards or previously established benchmarks, the pass/fail limits can be programmed into the LMG671 in order to allow the instrument to display the outcome of the test directly. Should there be different pass/fail criteria for consecutive DUTs, applicable limits can even be adjusted on-screen by the test engineer use the touchscreen GUI's input boxes or arrow keys. Some tests

require additional information (like e.g. magnetic path length, core diameter etc.) on the DUT that varies between tests and also needs to be considered for calculation. Also this kind of data can be entered and changed directly on-screen using a number of available input elements. These built-in decision-support features allow even less experienced or less well-trained users to reliably judge success or failure of the test.



Environment variables
In the example above, power P1 is compared to environment variable 1, which can be adjusted on-screen using the depicted arrow softkeys.

Signals
The values assumed by environment variables can be color-coded to alert the user to the status of the DUT or to indicate the outcome of the measurement e.g. pass/fail.

Switching keys
The status of the softkeys can be queried by the script. Those keys can act as push button, toggle or latching switches.

Five in one example: automated magnetic core testing

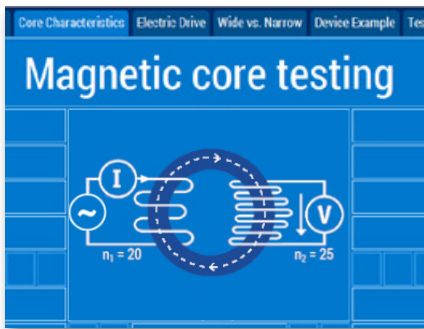

Magnetic Flux Density:
 $B_{pk} = 0.60800 \text{ T}$
 Magnetic Field Strength:
 $H_{pk} = 175.4024 \text{ A/m}$

```

25 //Characteristics and loss
26 Pfe = p11111?*$n1/$n2 //Power
27 Bpk = urec11111?/(4*fcyc111
    magnetic flux density
28 Hpk = Ipk*$n1/$lmagn // pe
29 ua = Bpk/0.0000012566/Hpk
    permeability
    
```

In this example the magnetic field strength and flux density from voltage, current and frequency measurements are calculated. The script editor offers a vast variety of mathematical, logical and procedural programming functions like loops and conditional execution of commands.

Make it easier to recognize your application: Add a meaningful title for your measurement. Use graphical elements like drawings or photographs to depict your setup and freely arrange them. Add your brand logo and reflect your corporate style in the choice of colors and design elements.

Sometimes, the formulae stored in the script editor require additional input, e.g. parameters that vary with every individual DUT, like material constants. No need to edit the stored scripts – these parameters can easily be entered on-screen by the executing engineer during testing. Arrow soft keys allow for in-/decrementing the chosen variables, and the number can be entered directly as well.

n_{prim} : \downarrow 20.0 \uparrow
 n_{sec} : \downarrow 25.0 \uparrow
 Cross section: \downarrow 6.5 m \uparrow
 Magn. Path length: \downarrow 100.0 m \uparrow

Add measurement values you are interested in, and only show what you need. You can display any electric quantity measured by the power channels as well as values from any I/O interface (CAN, PSI, GPIO).

Primary Current:
 $I_{prim} = 20.753 \text{ mA}$

Pass or fail criteria can be established in order to judge the suitability of the DUT for its intended purpose. The LMG600 allows to automate this decision based on the measured and calculated properties. The results of the test can be displayed in easily readable form to allow less skilled users to carry out testing without additional supervision.

Passed █

Clear visualization of measurements thanks to groups

The power channels can be organized in groups that define their role in the current measurement application. The groups appear almost as virtual measurement channels or virtual devices in addition to the physical channels. The logical grouping of the Power-channels is dependent on the number of wires and phases of the electrical system being analyzed. Thanks to the flexibility of the LMG600, it is possible to model even unusual and rarely seen configurations, such as split-phase systems and four-phase or multiphase systems.

The only requirement is that all of the channels within a group have the same basic frequency and are of the same type (S, A, B, C). This will avoid subtle errors, which arise due to the different technical properties of the different channel types. One benefit of creating groups is that it makes configuring the device easier, since filter settings (for example) affecting all channels in the group only have to be configured once. In addition, derived values, such as active, apparent or idle power are calculated across all channels in the group. While grouping

specifies how the channels are combined logically, the wiring dictates how the inputs of the measuring device are connected to the measuring circuit, i.e. whether it is a star-to-delta circuit or whether there are neutral wires, etc. The wiring defines how the measured signals are interpreted by the device.

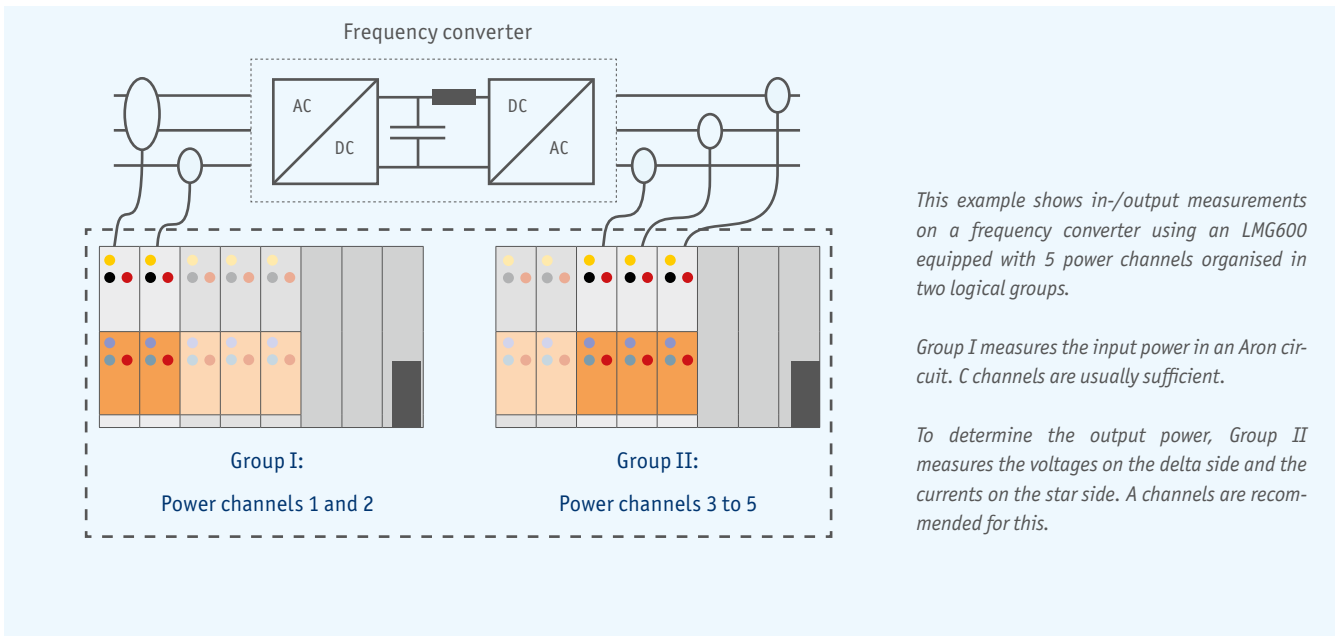

This example shows in-/output measurements on a frequency converter using an LMG600 equipped with 5 power channels organised in two logical groups.

Group I measures the input power in an Aron circuit. C channels are usually sufficient.

To determine the output power, Group II measures the voltages on the delta side and the currents on the star side. A channels are recommended for this.

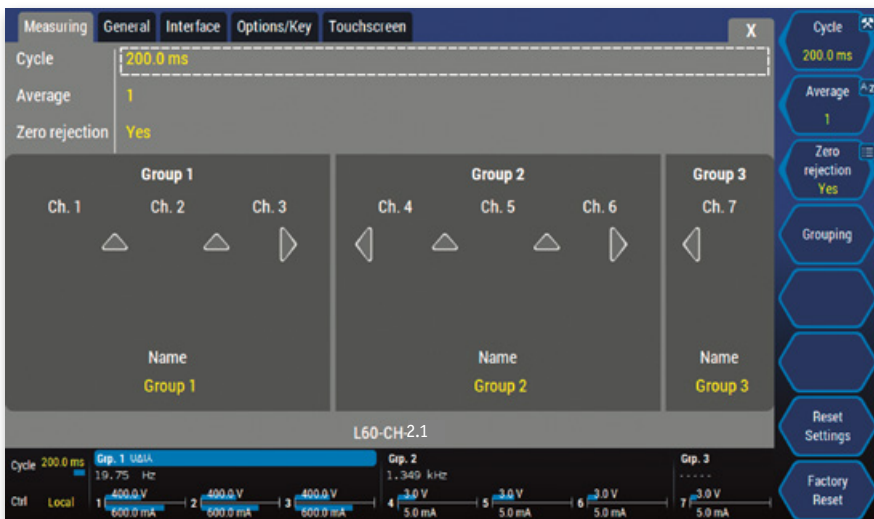

This screenshot depicts an example for logical grouping of an LMG600 fitted with 7 power channels, e.g. for measuring an electric drive. Group 1 & 2, with three channels each, could comprise the 3-phase input/output connections, while the single-channel Group 3 might represent the DC link.

LMG600 with 7 power channels organised in 3 groups

LMG Test Suite

Standards-compliant and meaningful

In modern power grids, the electromagnetic compatibility between all connected devices is ensured, when phenomena such as harmonic current emissions and flicker disturbance are strictly regulated. This is the scope of part of the IEC 61000 EMC standard family. The European Union is particularly demanding when it comes to electromagnetic compatibility, requiring from products that are intended for sale and distribution in its territory to bear the "CE" marking. The European Committee for Electrotechnical Standardization (Cenelec) commonly reviews the IEC international standards before they become European (EN) standards. The LMG Test Suite is a ZES ZIMMER developed software, used together with the LMG Power Analyzers to perform EMC compliance tests in accordance with the currently valid versions of the IEC/EN 61000-3-2/-12/-16* standards for harmonic emissions and the IEC/EN 61000-3-3/-11 standards for flicker disturbance. The software further supports measurements of standby power according to IEC 62301 & EN 50564. The LMG600 itself performs the harmonic analysis and flicker measurement according to the IEC/EN 61000-4-7 and IEC/EN 61000-4-15 standards.



IEC EN
61000-3-2/12
61000-3-16
61000-3-3/11
EN 50564
IEC 63201



Standard: EN 61000-4-7:2012 + A1:2019
Limits: EN 61000-3-2:2015 + A1:2021 (Table 1)
EMI (Class A)

Test name	% of Limit	Status	Details
Supply Voltage Frequency Test (50/60 Hz) [1]	OK	OK	50.00 Hz (50.00 Hz ± 0.5 %)
Supply peak voltage test (50/60 Hz) [1]	OK	OK	All positive peak values within the allowed range
Negative peak test	OK	OK	All negative peak values within the allowed range
Supply peak position test (50/60 Hz) [1]	OK	OK	All peak values within the allowed range
Supply Voltage Harmonic Distortion Test (1000-4-7) [1]	OK	OK	
Voltage Distortion H2	10%	OK	106 % ± 0.25 %
Voltage Distortion H3	3%	OK	102 % ± 0.80 %
Voltage Distortion H4	7%	OK	101 % ± 0.20 %
Voltage Distortion H5	7%	OK	101 % ± 0.45 %
Voltage Distortion H6	8%	OK	102 % ± 0.25 %
Voltage Distortion H7	10%	OK	101 % ± 0.20 %
Voltage Distortion H8	2%	OK	101 % ± 0.20 %
Voltage Distortion H9	11%	OK	102 % ± 0.20 %
Voltage Distortion H10	1%	OK	100 % ± 0.20 %
Voltage Distortion H11	25%	OK	102 % ± 0.10 %
Voltage Distortion H12	7%	OK	101 % ± 0.10 %
Voltage Distortion H13	22%	OK	102 % ± 0.10 %
Voltage Distortion H14	6%	OK	101 % ± 0.10 %
Voltage Distortion H15	32%	OK	101 % ± 0.10 %
Voltage Distortion H16	2%	OK	100 % ± 0.10 %
Voltage Distortion H17	22%	OK	102 % ± 0.10 %
Voltage Distortion H18	4%	OK	100 % ± 0.10 %
Voltage Distortion H19	10%	OK	102 % ± 0.10 %
Voltage Distortion H20	4%	OK	100 % ± 0.10 %
Voltage Distortion H21	3%	OK	102 % ± 0.10 %
Voltage Distortion H22	2%	OK	100 % ± 0.10 %
Voltage Distortion H23	19%	OK	102 % ± 0.10 %
Voltage Distortion H24	4%	OK	100 % ± 0.10 %
Voltage Distortion H25	18%	OK	102 % ± 0.10 %
Voltage Distortion H26	4%	OK	100 % ± 0.10 %
Voltage Distortion H27	17%	OK	102 % ± 0.10 %
Voltage Distortion H28	4%	OK	100 % ± 0.10 %
Voltage Distortion H29	10%	OK	102 % ± 0.10 %
Voltage Distortion H30	8%	OK	101 % ± 0.10 %
Voltage Distortion H31	3%	OK	102 % ± 0.10 %
Voltage Distortion H32	5%	OK	101 % ± 0.10 %
Voltage Distortion H33	22%	OK	102 % ± 0.10 %
Voltage Distortion H34	4%	OK	100 % ± 0.10 %
Voltage Distortion H35	22%	OK	102 % ± 0.10 %
Voltage Distortion H36	3%	OK	100 % ± 0.10 %
Voltage Distortion H37	19%	OK	102 % ± 0.10 %
Voltage Distortion H38	3%	OK	101 % ± 0.10 %
Voltage Distortion H39	18%	OK	102 % ± 0.10 %
Voltage Distortion H40	4%	OK	100 % ± 0.10 %
Frequency groups up to 9 kHz (50/60 Hz) [1]	OK	OK	
Table 1 Harmonic Current Test (1000-3-2) [1]	OK	OK	
Harmonic Current Test 100 %	OK	OK	
100 % Test #2	OK	OK	No test required (0.001 A ≤ 0.005 A)
100 % Test #3	1%	OK	Limit met (0.022 A ≤ 0.230 A)
100 % Test #4	OK	OK	No test required (0.001 A ≤ 0.005 A)
100 % Test #5	3%	OK	Limit met (0.011 A ≤ 1.140 A)
100 % Test #6	OK	OK	No test required (0.001 A ≤ 0.005 A)
100 % Test #7	4%	OK	Limit met (0.029 A ≤ 0.770 A)
100 % Test #8	OK	OK	No test required (0.001 A ≤ 0.005 A)
100 % Test #9	7%	OK	Limit met (0.027 A ≤ 0.200 A)
100 % Test #10	OK	OK	No test required (0.001 A ≤ 0.005 A)
100 % Test #11	7%	OK	Limit met (0.028 A ≤ 0.110 A)

Innovative power measurement technology

The LMG Test Suite employs the LMG600's proven excellence in precision power measurement. All ZES ZIMMER power analyzers measure with particularly great reliability and precision. The instrument itself does not only serve as compliance testing hardware, but is also a powerful R&D tool. Among its various interfaces, a fast Ethernet (Gbit) port guarantees smooth communication and data transfer between the software and hardware.



Detailed analysis for rapid diagnostics and product improvement

Compliance tests with the LMG Test Suite are carried out either online through direct connection with the LMG600 or offline by using stored data records. Each relevant measurement parameter can be displayed and evaluated in the time and/or frequency domain. This helps the user to quickly identify and address causes of non-compliance. All measured data points and test results can be exported in csv format for further analysis. At the same time, the connection with the LMG600 is quick and seamless.

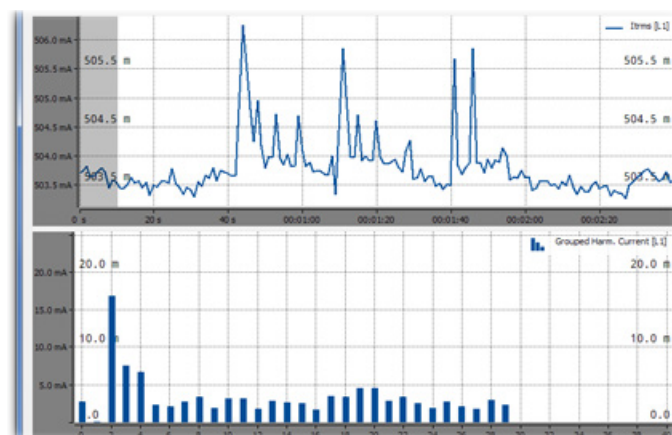

Flexible hardware use, independent of manufacturer

The LMG Test Suite supports all AC power sources available on the market that comply with the standards. This provides maximum flexibility to the user. In particular, as long as the user owns an AC source that complies to the requirements of the desired tests, they may continue using the source that they already have in possession and thus avoid additional investments. At the same time, ZES ZIMMER is in position to recommend and supply an AC sources from third party manufacturers. Standards-specific calibration of the source is not necessary, as the test system monitors the compliance to the specified source parameters. For instance, the system analyzes the source's voltage harmonics and presents them graphically. Any problems from this side of the test structure are thus reliably excluded.

Comprehensive, customer-specific documentation

All results are documented in clear, comprehensive PDF/Word/Excel test reports. According to the standard, the test report may be based on information supplied by the manufacturer to a testing facility, or be a document recording details of the manufacturer's own tests. It includes all relevant information for the test conditions, the test observation period, alongside with the appointed measurement values. All data regarding the measurement equipment, test structure and settings -such as type designations, serial numbers and information on the calibration and traceability- is also integrated into the test reports. Of course, the reports can be supplemented with additional customer-specific information and design elements, in order to avoid unnecessary post-editing outside the system.

Test Report

was tested according to
EN 61000-4-7:2002 + A1:2009
EN IEC 61000-3-2:2019 + A1:2021 (Table 1)
Test result was
OK

Test Settings

Test	
Measuring Standard	EN 61000-4-7:2002 + A1:2009
Limits	EN IEC 61000-3-2:2019 + A1:2021 (Table 1)
Test Date	19.03.2019
Test Time	08:37:00
Measurement Duration	00:02:30
EUT Classification	Class A
EUT / Measurement Setup	
Power Supply	
Nominal Voltage	230 V
Nominal Frequency	50 Hz

Constant support of existing and upcoming standards

The LMG Test Suite supports compliance tests according to the following standards:

- IEC/EN 61000-4-7: Testing and measurement techniques - General guide on harmonics and interharmonics measurements and instrumentation for power supply systems and equipment connected thereto.
- IEC/EN 61000-3-2: Limits - Limits for harmonic current emissions (equipment input current ≤ 16 A per phase).
- IEC/EN 61000-3-12: Limits - Limits for harmonic currents produced by equipment connected to public low-voltage systems with input current > 16 A and ≤ 75 A per phase.
- IEC 61000-3-16*: Limits - Limits for harmonic currents produced by energy-supplying equipment with a rated current less than or equal to 75 A per phase connected to public low-voltage systems.
- IEC/EN 61000-4-15: Testing and measurement techniques - Flickermeter - Functional and design specifications.
- IEC/EN 61000-3-3: Limits - Limitation of voltage changes, voltage fluctuations, and flicker in public low-voltage supply systems for equipment with rated current ≤ 16 A per phase and not subject to conditional connection.
- IEC/EN 61000-3-11: Limits - Limitation of voltage changes, voltage fluctuations, and flicker in public low-voltage supply systems - Equipment with rated current ≤ 75 A and subject to conditional connection.
- EN 50564: Electrical and electronic household and office equipment - Measurement of low power consumption.
- IEC 62301: Household electrical appliances - Measurement of standby power

ZES ZIMMER, as a manufacturer of precision power measurement technology, is represented in the international standards committee. As a result, all upcoming changes in the standards are observed and immediately incorporated into the test software.

*05/2022: Support of the current Comitee Draft version of the standard.

Applications

Application Electrical drive systems

More than half of the electrical energy generated worldwide is converted to mechanical motion, and the importance of electric powertrains for transport of goods and people is growing steadily. While outdated speed controllers are afflicted with losses of up to 40%, modern, frequency-controlled systems can achieve efficiency levels of over 95%. These frequency converters use pulse

width modulation to control the speed of the motor with hardly any losses. The objective is to optimally adjust the converter and motor to one another, in order to achieve the best overall efficiency. Measuring the input power, the intermediate circuit, and the output power of the converter as well as the mechanical power of the motor simultaneously is anything but trivial. In addition to

the integration of sensor technology (wide-band sensors for high currents, high-voltage dividers, precise speed and torque transmitters), the instrument must meet the challenge of measuring the very steep-flanked signals at the converter output. This environment is often described as harsh, not merely from an EMC point of view.

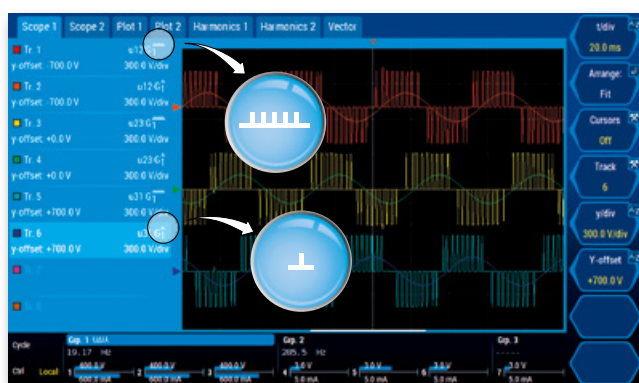
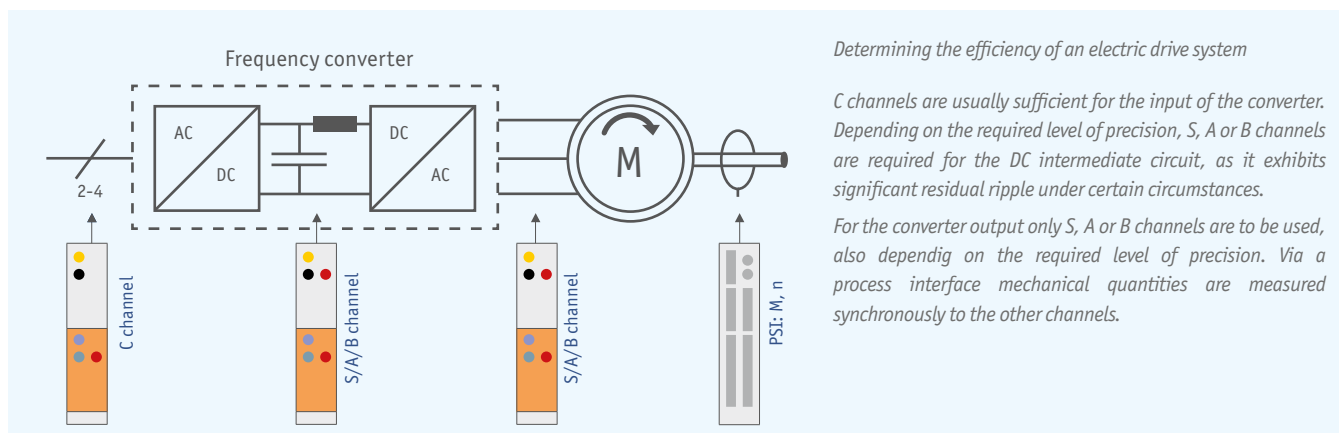

Scope display of the voltages at the converter output. The wideband values (⏏) show the PWM signal, the narrowband values (⏏) are sinusoidal.

Of course the key question in the analysis of electrical drive systems is: which part of the electrical energy at the converter output relates to the torque-relevant fundamental frequency of the motor, and which part to

the remaining frequency range, particularly the harmonic spectrum? To give an accurate answer, it has long been necessary to perform two separate measurements: one without filters to establish the wideband power,

and another one on a filtered signal to determine the power at certain frequencies, resp. a subsequent FFT analysis to measure the harmonic spectrum. This procedure is very time-consuming, yet it cannot guarantee that the conditions present during the initial measurement still prevail during the repetition.

The innovative DualPath architecture of the LMG600 provides all of the required results simultaneously in a single measurement, with maximum precision, and the widest frequency range on the market – free from aliasing effects.

CHALLENGES

- Synchronous measurement of speed and torque
- Highly accurate measurement of the fundamental oscillation relevant to torque
- Simultaneous aliasing-free measurement of losses across maximum frequency range
- Range expansion for high current and medium voltage applications
- Fast data export to third-party devices and applications

- ✓ DualPath
- ✓ S/A/B/C Channels
- ✓ Harmonics
- ✓ Star-to-Delta
- ✓ Accuracy
- ✓ Immunity
- ✓ Interfaces
- ✓ Plug 'n' Measure

EV chargers testing and certification

A precise power measuring instrument like the LMG600 series power analyzer can be seamlessly integrated into compliance test benches by charging station manufacturers and certifying institutions. It can serve as a traceable standard for type examination certification and is an excellent tool for verifying proper charging functioning in case of any doubts. Charging stations are equipped with a single or multiple charging plugs of type 2, CCS, CHAdeMO or other to provide AC and/or DC charging. Integrated certified energy meters for each charging plug measure the energy consumed for the complete charging process. The meter communicates its reading to the system back-

end for billing purposes. The voltage and current signals are fed into the power analyzer via breakout boxes. Voltage drops that may occur are typically negligibly small. For AC type 2 charging plugs, the current must not exceed 32 A and can directly be connected to the power analyzer's inputs. Particularly fast DC charging results in current values of several 100 A which require a very accurate current sensor, like the PCT sensor with its outstanding Flux-Gate technology. Additionally, the energy meter's pulse output is connected to the LMG671 process-signal-interface (PSI) switching input, allowing the analyzer to capture the pulses during the complete charging pro-

cess to determine the energy metered by the charging station. The type examination test procedure specifies a measurement over a minimum number of leaps of the lowest value digit, which corresponds to a minimum number of pulses. This number depends on the device to be charged and the point of operation chosen. The higher the charging power, the higher the prescribed minimum number of pulses. Otherwise, the observed time window will be too short, and the uncertainty of the internal clock will have an undue influence on observed measurement accuracy.

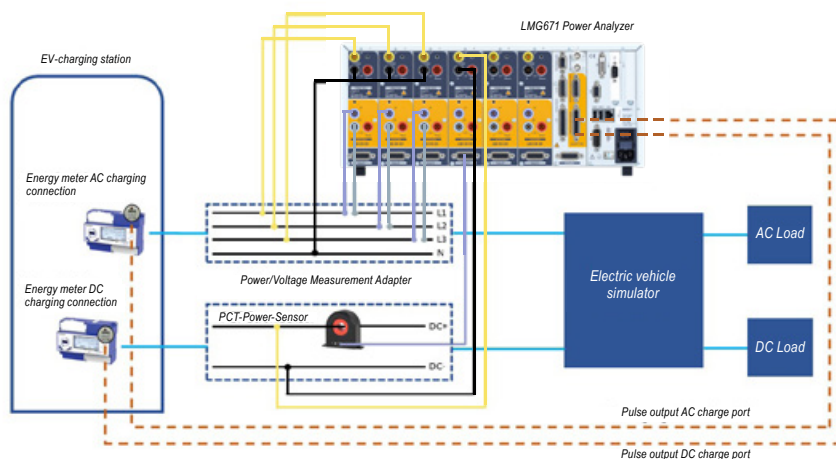

Measuring setup with LMG671 and PCT current sensor

The module B, respectively EU-type examination test for certification, stipulates to verify the accuracy of the complete charging process by comparing the energy metered at each charging port with the energy measured by a reference instrument.

This can be a precise power analyzer like the LMG671 wired between the energy meter and electric vehicle.

The figure on the left side shows a possible measuring setup with an LMG671 power analyzer as reference instrument.

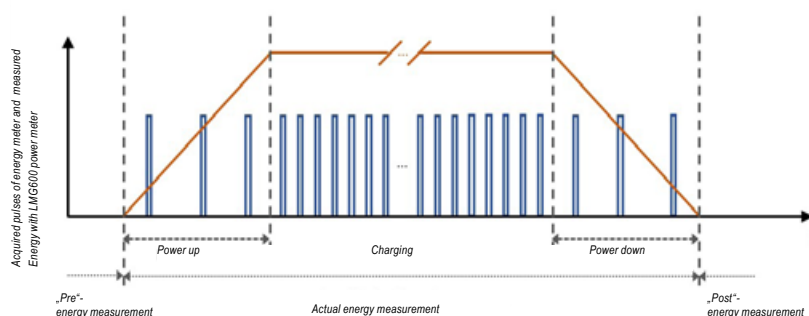

Energy meter pulses captured and energy measured by the LMG600 power analyzer

The LMG671 switching inputs are sampled with 150 kHz. Standardized energy meter pulse signals will be reliably captured and counted.

Depending on the charging power level and specified pulses per kilowatt-hour of the integrated energy meter, the fastest measuring cycle time of 10 ms (or 20 ms considering a 50 Hz signal) allows to count the pulses captured almost one by one.

This is important to ensure the number of captured pulses during the energy integration interval is accurate.

Specifications

Accuracy specification

S channel Accuracy	± (% of measured value + % of maximum peak value)
	DC ^{e)}
Voltage U*	0.02+0.04
Voltage U _{SENSOR}	0.02+0.04 ^{d)}
Current I* 5 mA...5 A range AC, 10 mA...8 A range DC	0.02+0.04
Current I* 10 A...32 A range AC, 15 A...32 A range DC	0.02+0.1 ^{g)}
Current I _{SENSOR}	0.02+0.04 ^{d)}
Active Power	$\Delta P_{DC} = \pm(\Delta U_{DC} \cdot I_{DC} + \Delta I_{DC} \cdot U_{DC})$ Description of the used formula symbols, see ACCURACY SPECIFICATIONS in the manual

^{e)} Accuracy specification is valid with activated automatic zero adjustment, max. 24 h after last change of the measuring range in the current measurement channel at jack I*, temperature change after change of the measuring range max. ±1 °C, max.30 days after persistent zero adjustment in the voltage measurement channel at the jacks U* and Usensor and in the current measurement channel at jack Isensor (see ZERO ADJUSTMENT in the manual)

^{d)} Accuracy specification is valid with activated signal filter 15 kHz or 150 kHz

^{g)} Additional accuracy specification in the 10 A ... 32 A range AC or 15 A ...32 A range DC: $\pm \frac{80 \mu A}{A^2} \cdot I_{rms}^2$

S channel Accuracy									
	0.05 Hz ... 45 Hz 65 Hz ... 3 kHz	45 Hz ... 65 Hz	3 kHz ... 10 kHz	10 kHz ... 50 kHz	50 kHz ... 100 kHz	100 kHz ... 500 kHz	500 kHz...1 MHz	1 MHz ... 2 MHz	2 MHz ... 10 MHz
Voltage U*	0.015+0.03	0.01+0.02	0.03+0.06	0.2+0.4		0.5+1.0	0.5+1.0	f/1MHz*1.5 + f/1MHz*1.5	
Voltage U _{SENSOR}	0.015+0.03	0.01+0.02	0.03+0.06	0.2+0.4		0.4+0.8	0.4+0.8	f/1MHz*0.7 + f/1MHz*1.5	
Current I* 5 mA...5 A range AC, 10 mA...8 A range DC	0.015+0.03	0.01+0.02	0.03+0.06	0.2+0.4		0.5+1.0	0.5+1.0	f/1 MHz*1.0 + f/1 MHz*2.0	-
Current I* 10 A...32 A range AC, 15 A...32 A range DC	0.015+0.03 ^{g)}	0.01+0.02 ^{g)}	0.1+0.2 ^{g)}	0.3+0.6 ^{g)}	f/100 kHz*0.8 + f/100 kHz*1.2 ^{g)}		-	-	-
Current I _{SENSOR}	0.015+0.03	0.01+0.02	0.03+0.06	0.2+0.4		0.4+0.8	0.4+0.8	f/1MHz*0.7 + f/1MHz*1.5	
Power U*/I* 5 mA...5 A range AC, 10 mA...8 A range DC	0.024+0.03	0.015+0.01	0.048+0.06	0.32+0.4		0.8+1.0	0.8+1.0	f/1 MHz*2.0 + f/1 MHz*1.8	-
Power U*/I* 10 A...32 A range AC, 15 A...32 A range DC	0.024+0.03 ^{g)}	0.015+0.01 ^{g)}	0.104+0.13 ^{g)}	0.4+0.5 ^{g)}	f/100 kHz*0.8+ f/100 kHz*0.8 ^{g)}	f/100 kHz*1.0 + f/100 kHz*1.1 ^{g)}	-	-	-
Power U*/I _{SENSOR}	0.024+0.03	0.015+0.01	0.048+0.06	0.32+0.4		0.72+0.9	0.72+0.9	f/1MHz*1.8 + f/1MHz*1.5	
Power U _{SENSOR} /I* 5 mA...5 A range AC, 10 mA...8 A range DC	0.024+0.03	0.015+0.01	0.048+0.06	0.32+0.4		0.72+0.9	0.72+0.9	f/1 MHz*1.4 + f/1 MHz*1.8	-
Power U _{SENSOR} /I* 10 A...32 A range AC, 15 A...32 A range DC	0.024+0.03 ^{g)}	0.015+0.01 ^{g)}	0.104+0.13 ^{g)}	0.4+0.5 ^{g)}	f/100 kHz*0.8+ f/100 kHz*0.8 ^{g)}	f/100 kHz*1.0 + f/100 kHz*1.0 ^{g)}	-	-	-
Power U _{SENSOR} /I _{SENSOR}	0.024+0.03	0.015+0.01	0.048+0.06	0.32+0.4		0.64+0.8	0.64+0.8	f/1MHz*1.1 + f/1MHz*1.5	

^{g)} Additional accuracy specification in the 10 A ... 32 A range AC or 15 A ...32 A range DC: $\pm \frac{80 \mu A}{A^2} \cdot I_{rms}^2$

^{g)} Additional accuracy specification in the 10 A ... 32 A range AC or 15 A ...32 A range DC: $\pm \frac{80 \mu A}{A^2} \cdot I_{rms}^2 \cdot U_{rms}$

Accuracy specification

A channel Accuracy	± (% of measured value + % of maximum peak value)										
	DC	DC ^{e)}	0.05 Hz ... 45 Hz 65 Hz ... 3 kHz	45 Hz ... 65 Hz	3 kHz ... 10 kHz	10 kHz ... 50 kHz	50 kHz ... 100 kHz	100 kHz ... 500 kHz	500 kHz ... 1 MHz	1 MHz ... 2 MHz	2 MHz ... 10 MHz
Voltage U*	0.02+0.08	0.02+0.06 ^{e)}	0.015+0.03	0.01+0.02	0.03+0.06	0.2+0.4		0.5+1.0	0.5+1.0	f/1 MHz*1.5 + f/1 MHz*1.5	
Voltage U _{SENSOR}	0.02+0.08	0.02+0.06 ^{e)}	0.015+0.03	0.01+0.02	0.03+0.06	0.2+0.4		0.4+0.8	0.4+0.8	f/1 MHz*0.7 + f/1 MHz*1.5	
Current I* 5 mA ... 5 A	0.02+0.1	0.02+0.06 ^{e)}	0.015+0.03	0.01+0.02	0.03+0.06	0.2+0.4		0.5+1.0	0.5+1.0	f/1 MHz*1.0 + f/1 MHz*2.0	-
Current I* 10 A ... 32 A	0.02+0.1 ¹⁾	-	0.015+0.03 ¹⁾	0.01+0.02 ¹⁾	0.1+0.2 ¹⁾	0.3+0.6 ¹⁾	f/100 kHz*0.8 + f/100 kHz*1.2 ¹⁾		-	-	-
Current I _{SENSOR}	0.02+0.08	0.02+0.06 ^{e)}	0.015+0.03	0.01+0.02	0.03+0.06	0.2+0.4		0.4+0.8	0.4+0.8	f/1 MHz*0.7 + f/1 MHz*1.5	
Power U*/I* 5 mA ... 5 A	0.032+0.09	0.032+0.06 ^{e)}	0.024+0.03	0.015+0.01	0.048+0.06	0.32+0.4		0.8+1.0	0.8+1.0	f/1 MHz*2.0 + f/1 MHz*1.8	-
Power U*/I* 10 A ... 32 A	0.032+0.09 ²⁾	-	0.024+0.03 ²⁾	0.015+0.01 ²⁾	0.104+0.13 ²⁾	0.4+0.5 ²⁾	f/100 kHz*0.8 + f/100 kHz*0.8 ²⁾	f/100 kHz*1.0 + f/100 kHz*1.1 ²⁾	-	-	-
Power U*/I _{SENSOR}	0.032+0.08	0.032+0.06 ^{e)}	0.024+0.03	0.015+0.01	0.048+0.06	0.32+0.4		0.72+0.9	0.72+0.9	f/1 MHz*1.8 + f/1 MHz*1.5	
Power U _{SENSOR} /I*	0.032+0.09	0.032+0.06 ^{e)}	0.024+0.03	0.015+0.01	0.048+0.06	0.32+0.4		0.72+0.9	0.72+0.9	f/1 MHz*1.4 + f/1 MHz*1.8	-
Power U _{SENSOR} /I* 10 A ... 32 A	0.032+0.09 ²⁾	-	0.024+0.03 ²⁾	0.015+0.01 ²⁾	0.104+0.13 ²⁾	0.4+0.5 ²⁾	f/100 kHz*0.8 + f/100 kHz*0.8 ²⁾	f/100 kHz*1.0 + f/100 kHz*1.0 ²⁾	-	-	-
Power U _{SENSOR} /I _{SENSOR}	0.032+0.08	0.032+0.06 ^{e)}	0.024+0.03	0.015+0.01	0.048+0.06	0.32+0.4		0.64+0.8	0.64+0.8	f/1 MHz*1.1 + f/1 MHz*1.5	

B channel Accuracy	± (% of measured value + % of maximum peak value)						
	DC	0.05 Hz ... 45 Hz 65 Hz ... 1 kHz	45 Hz ... 65 Hz	1 kHz ... 5 kHz	5 kHz ... 20 kHz	20 kHz ... 100 kHz	100 kHz ... 500 kHz
Voltage U*	0.1+0.1	0.1+0.1	0.03+0.03	0.2+0.2	0.3+0.4	0.4+0.8	f/100 kHz*0.8 + f/100 kHz*1.2
Current I* 5 mA ... 5 A Current I _{SENSOR}	0.1+0.1	0.1+0.1	0.03+0.03	0.2+0.2	0.3+0.4	0.4+0.8	f/100 kHz*0.8 + f/100 kHz*1.2
Current I* 10 A ... 32 A	0.1+0.1 ¹⁾	0.1+0.1 ¹⁾	0.03+0.03 ¹⁾	0.2+0.2 ¹⁾	0.6+1.2 ¹⁾	1.5+1.5 ¹⁾	f/100 kHz*2.0 + f/100 kHz*2.0 ¹⁾
Power U*/I* 5 mA ... 5 A Power U*/I _{SENSOR}	0.16+0.1	0.16+0.1	0.05+0.02	0.32+0.2	0.48+0.4	0.64+0.8	f/100 kHz*1.28 + f/100 kHz*1.2
Power U*/I* 10 A ... 32 A	0.16+0.1 ²⁾	0.16+0.1 ²⁾	0.05+0.02 ²⁾	0.32+0.2 ²⁾	0.72+0.8 ²⁾	1.52+1.15 ²⁾	f/100 kHz*2.24 + f/100 kHz*1.6 ²⁾

C channel Accuracy	± (% of measured value + % of maximum peak value)						
	DC	0.05 Hz ... 45 Hz 65 Hz ... 200 Hz	45 Hz ... 65 Hz	200 Hz ... 500 Hz	500 Hz ... 1 kHz	1 kHz ... 2 kHz	2 kHz ... 10 kHz
Voltage U*	0.1+0.1	0.02+0.05	0.02+0.02	0.05+0.05	0.2+0.1	1.0+0.5	f/1 kHz*1.0 + f/1 kHz*1.0
Current I*	0.1+0.1 ¹⁾	0.02+0.05 ¹⁾	0.02+0.02 ¹⁾	0.05+0.05 ¹⁾	0.2+0.1 ¹⁾	1.0+0.5 ¹⁾	f/1 kHz*1.0 + f/1 kHz*1.0 ¹⁾
Current I _{SENSOR}	0.1+0.1	0.02+0.05	0.02+0.02	0.05+0.05	0.2+0.1	1.0+0.5	f/1 kHz*1.0 + f/1 kHz*1.0
Power	0.16+0.1 ²⁾	0.032+0.05 ²⁾	0.03+0.01 ²⁾	0.08+0.05 ²⁾	0.32+0.1 ²⁾	1.6+0.5 ²⁾	f/1 kHz*1.6 + f/1 kHz*1.0 ²⁾

Accuracies valid for:	1. Sinusoidal voltages and currents 2. Ambient temperature (23±3) °C 3. Warm-up time 1 h 4. The maximum peak value for power is the product of the maximum peak value for voltage and the maximum peak value for current.	5. 0 ≤ λ ≤ 1 (power factor) 6. Current and voltage 10% ... 110% of nominal value 7. Adjustment carried out at 23 °C 8. Calibration interval 12 months
Other values	All other values are calculated from current, voltage and power. Accuracy resp. error limits are derived according to context (e.g. S = I * U, ΔS / S = ΔI / I + ΔU / U).	

¹⁾ only valid in range 10 ... 32 A:

¹⁾ additional uncertainty $\pm \frac{80 \mu A}{A^2} * I_{\text{rms}}^2$ ²⁾ additional uncertainty $\pm \frac{80 \mu A}{A^2} * I_{\text{rms}}^2 * U_{\text{rms}}$

^{e)} Accuracy specification after non-persistent zero adjustment, temperature change after zero adjustment max. ±1 °C

Measuring ranges for S - Channel

Voltage measuring ranges U*										
Nominal value AC / V	3	6	12.5	25	60	130	250	400	600	1000
Nominal value DC / V	5	10	20	45	90	180	360	720	1000	1500 ^{xx}
Max. trms value / V	5.5	11	22	47	95	190	370	730	1010 [*]	1510 ^x
Max. peak value / V	6	12	25	50	100	200	400	800	1600	3200
Input impedance	2.69 MΩ ± 1% 4 pF									
Overload protection	UAC = 1000V + 10% continuously UAC = 1500V for 1 s UDC = 1500V + 10% continuously ^{xx} U = 2500V for 20 ms, transient									
Earth capacitance	approx. 90 pF									

* See specification of overload capability, max. measurable RMS values, max. Isolation voltage and the warnings at the beginning of this section

^{xx} With additional adapter L60-CH-S-VRE

Current measuring ranges I*								
Nominal value AC / A	0.005	0.01	0.02	0.04	0.08	0.15	0.3	0.6
Nominal value DC / A	0.01	0.02	0.04	0.08	0.15	0.3	0.6	1.2
Max. trms value A	0.011	0.021	0.042	0.084	0.16	0.32	0.64	1.25
Max. peak value A	0.014	0.028	0.056	0.112	0.224	0.469	0.938	1.875
Input impedance	approx. 2.2 Ω + 200 nH		approx. 600 mΩ + 200 nH			approx. 80 mΩ + 200 nH		
Overload protection	LMG in operation, 10 A continuously, 150 A for 10 ms							
Earth capacitance	about. 90 pF							

Current measuring ranges I*						
Nominal value AC / A	1.2	2.5	5	10	20	32
Nominal value DC / A	2.5	5	8	15	22	32
Max. trms value A	2.6	5.2	8.4	15.5	22.5	32.5 ^x
Max. peak value A	3.75	7.5	15	30	60	120
Input impedance	approx. 20 mΩ + 200 nH			approx. 10 mΩ + 200 nH		
Overload protection	LMG in operation, 32 A continuously, 150 A for 10 ms					
Earth capacitance	about. 90 pF					

Sensor input U _{SENSOR} I _{SENSOR}								
Nominal value AC / V	0.03	0.06	0.12	0.25	0.5	1	2	4
Nominal value DC / V	0.08	0.15	0.3	0.6	1.2	2.5	5	10
Max. trms value V	0.085	0.16	0.32	0.65	1.3	2.75	5.5	11
Max. peak value V	0.0977	0.1953	0.3906	0.7813	1.563	3.125	6.25	12.5
Input impedance	99,8 kΩ ± 1% 34 pF							
Overload protection	100 V continuously, 250 V for 1 s							
Earth capacitance	about. 90 pF							

This channel is rated for measuring voltages from ☉ U* to ☉ U up to:

- U_{AC} = U_{DC} = 300V, measurement category CAT IV
- U_{AC} = U_{DC} = 600V, measurement category CAT III
- U_{AC} = U_{DC} = 1000V measurement category CATII
- U_{DC} = 1500V with additional adapter L60-CH-S-VRE

This channel is rated for insulation voltages from ☉ U*, ☉ U, ☉ U_{SENSOR}, ☉ I*, ☉ I, ☉ I_{SENSOR} to protective earth PE and from ☉ U to ☉ I up to:

- U_{AC} = U_{DC} = 300V, measurement category CAT IV
- U_{AC} = U_{DC} = 600V, measurement category CAT III
- U_{AC} = U_{DC} = 1000V measurement category CATII

Measuring ranges for A / B / C - Channels





Voltage measuring ranges U*										
Nominal value (V)	3	6	12.5	25	60	130	250	400	600	1000
Max. trms value (V)	3.3	6.6	13.8	27.5	66	136	270	440	660	1000
Max. peak value (V)	6	12	25	50	100	200	400	800	1600	3200
Overload protection	1000V + 10% continuously, 1500V for 1s, 2500V for 20ms									
Input impedance	2.69 MΩ 4 pF									
Earth capacitance	about. 90 pF									

Current measuring ranges I*														
Nominal value (A)	0.005	0.01	0.02	0.04	0.08	0.15	0.3	0.6	1.2	2.5	5	10	20	32
Max. trms value (A)	0.0055	0.011	0.022	0.044	0.088	0.165	0.33	0.66	1.32	2.75	5.5	11	22	32
Max. peak value (A)	0.014	0.028	0.056	0.112	0.224	0.469	0.938	1.875	3.75	7.5	15	30	60	120
Input impedance	approx. 2.2 Ω		approx. 600 mΩ			approx. 80 mΩ			approx. 20 mΩ			approx. 10 mΩ		
Overload protection permanent (A)	LMG in operation 10 A									LMG in operation 32 A				
Overload protection short-time (A)	150 A for 10 ms													
Earth capacitance	about. 90 pF													

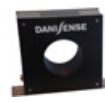

Sensor inputs U _{SENSOR} / I _{SENSOR}									
Nominal value (V)	0.03	0.06	0.12	0.25	0.5	1	2	4	
Max. trms value (V)	0.033	0.066	0.132	0.275	0.55	1.1	2.2	4.4	
Max. peak value (V)	0.0977	0.1953	0.3906	0.7813	1.563	3.125	6.25	12.5	
Overload protection	100V continuously, 250V for 1s								
Input impedance	100 kΩ 34 pF								
Earth capacitance	about. 90 pF								

Isolation	All current and voltage inputs are isolated against each other, against remaining electronics and against earth. Max. 1000 V / CAT II resp. 600 V / CAT III resp. 300 V / CAT IV
Synchronization	Measurements are synchronized on the signal period. The period is determined based on „external“, u(t) or i(t), in combination with configurable filters. Therefore readings are very stable, especially with PWM controlled frequency converters and amplitude modulated electronic loads.
Scope function	Graphical display of sample values over time in two scopes with 8 signals each
Plot function	Two time (trend-) diagrams of max. 8 parameters each, max. resolution 10 ms
External graphics interface (L671-OPT-DVI)	DVI interface for external screen output
Process signal interface (L6-OPT-PSI)	2 fast analog inputs (150 kS/s, 16 bit, BNC) 8 analog inputs (100 S/s, 16 bit, D-Sub:DE-09) 32 analog outputs (output per cycle, 14 bit, D-Sub: DA-15 & DB-25) 8 switching outputs (6 switches with 2 connections each and 2 switching outputs with common negative, D-Sub: DB-25) 8 switching inputs (150 kS/s, in two groups 4 inputs each with common ground, D-Sub: DB-25) Speed-/torque-/frequency inputs (150 kS/s, D-Sub: DA-15)
Star-delta conversion (L6-OPT-SDC)	Conversion of line voltages to phase voltages and computation of resulting active power
Harmonics at device level (L6-OPT-HRM)	Harmonics and interharmonics up to 2,000th order, independent and simultaneously for each group
Flicker (L6-OPT-FLK)	According to IEC EN 61000-4-15
LMG Remote	LMG600 expansion software, basic module for remote configuration and operation via PC
LMG Test Suite	LMG600 software for conformity tests according to: IEC EN 61000-3-2 & 61000-3-12 for harmonics (LMG-TEST-CE-HRM) IEC EN 61000-3-3 & 61000-3-11 for flicker (LMG-TEST-CE-FLK) IEC 62301 & EN 50564 for standby power (LMG-TEST-CE-STBY)
Miscellaneous	
Dimensions (WxHxD)	LMG671: Table-top version: 433 mm x 177 mm x 590 mm, 19" version: 84 HP x 4 RU x 590 mm, LMG641: Table-top version: 284 mm x 177 mm x 590 mm, 19" version: 84 HP x 4 RU x 590 mm, LMG611: Table-top version: 433 mm x 177 mm x 200 mm, LMG671-ATE: 84 HP x 4 RU x 590 mm
Display	LMG671: 10.1", 1280 x 800 px, LMG641 & LMG611: 7", 1024 x 600 px, LMG671-ATE: None
Weight	Depending on the numbers of installed channels and options. LMG671 & LMG671-ATE: Max. 18.5 kg, LMG641: Max. 15.5 kg, LMG611: Max. 7.2 kg
Protection class	All: EN 61010 (IEC 61010, VDE 0411), protection class I / IP20 in accordance with EN 60529
Electromagnetic compatibility	All: EN 61326
Temperature	All: 5 ... 40 °C (operation) / -20 ... 50 °C (storage)
Climatic category	All: Normal environmental conditions according to EN 61010
Line input	LMG671 & LMG671-ATE: 100 ... 230V, 47 ... 63 Hz, max. 400 W, LMG641 & LMG611: 100 ... 230V, 47 ... 63 Hz, max. 200 W

Accessories Program (Excerpt)

Current sensors					
Type	Ring-type transducers				Current clamps
					
Name	PCT	Halbxxx-L6	Danisense Current Sensors	LMG-Z7XX	L60-Z406, L60-Z60/66
Signal type	AC+DC				AC
Current ranges	200...2000 A _{rms}	100...2000 A _{rms}	50...7000 A _{rms}	750 A _{rms} ... 10 kA _{rm}	40...3 kA _{rms}
Best accuracy	0.01 %	0.5 %	0.01 %	0.02 %	0.2 %
Max. bandwidth	DC...1 MHz	DC...100 kHz	DC...1 MHz	20 Hz ...500 Hz	5 Hz...50 kHz
Power supply	PCT200/600/1200	Yes	No	Not required	Yes
Plug 'n' Measure	PCT200/600/1200	Yes	No	No	Yes

High-voltage dividers				
				
Name	HST3	HST6	HST9	HST12
Signal type	AC+DC			
Max. voltage	3.5 kV _{eff}	7 kV _{eff}	10.5 kV _{eff}	14 kV _{eff}
Best accuracy	0.05 %			
Max. bandwidth	0 Hz...300 kHz			
# of phases	1 to 3			
Plug 'n' Measure	No			

Breakout boxes				
				
Name	LMG-MAS	LMG-MAK1	BOB-CEE3-16	BOB-CEE3-32
Nominal voltage	250 V	250 V	230 / 400 V	
Category	CAT II		CAT II	
Safety standard	IEC / EN61010-1		IEC / EN61010-1	
Socket for load connection	16 A 250V CEE 7/4	10 A 250V IEC 60320-C14	16 A 400V 3L+N+PE, 6 h IEC 60309	32 A 400V 3L+N+PE, 6 h IEC 60309
The Breakout Boxes enable access to the individual lines in a connector for measurement, and provide an easy and elegant way to take measurements on single and three-phase consumers.				

LMG Remote

The LMG Remote PC software allows to easily control the LMG600 remotely from a Windows PC. Since this software mimics the measuring device itself down to the last detail, the LMG600 can be operated as usual, even from the PC - no rethinking required, no familiarization time.

LMG Test Suite

The tests performed by LMG Test Suite are in accordance with the currently valid edition of EN 61000-3-2/-12, EN 61000-3/-11, IEC 62301 and EN 50564. Measurements according to ECE R-10.4 Annex 11 (electromagnetic compatibility of vehicles), for example, are also possible.

R&S Ordering Information

Designation	Type	Order No.
Choose your base unit		
Power Analyzer 7 Channels Base Unit	LMG671-BAS	1603.5892.02
Power Analyzer 7 Channels ATE Base Unit	LMG671-ATE	1603.5886.02
Power Analyzer 4 Channels Base Unit	LMG641-BAS	1603.0003.02
Single Channel Power Analyzer: A-Channel	LMG611-A3	1603.5970.02
Single Channel Power Analyzer: B-Channel	LMG611-B2	1603.0049.02
Single Channel Power Analyzer: C-Channel	LMG611-C2	1603.5905.02
Choose your channels (Does not apply to LMG611)		
S-Channel: High-precision wideband DC-optimized measurements up to 10 MHz	L60-CH-S3	1603.5934.02
A-Channel: High-precision wideband measurements up to MHz	L60-CH-A2	1603.0132.02
B-Channel: Universal measurements up to 500 kHz	L60-CH-B3	1603.5911.02
C-Channel: High precision measurements up to 10 kHz	L60-CH-C2	1603.5928.02
Process Signal Interface	L60-OPT-PSI	1603.0110.02
S-Channel: Voltage range extension to 1500 VDC	L60-CH-S-V	1603.1097.02
Choose your hardware options		
CAN Bus Interface	L6-OPT-CAN	1603.0849.02
DVI Interface	L6X1-DVI	1603.0903.02
256 GB Mass Storage	L6X1-MS256	1603.0910.02
Choose your software options		
Event Triggering	L6-OPT-EVT	1603.0855.02
Flicker Meter according to EN 61000-4-15	L6-OPT-FLK	1603.0861.02
Harmonic Analysis of U, I, P, Q and S	L6-OPT-HRM	1603.0878.02
Star to Delta Conversion	L6-OPT-SDC	1603.0826.02
Smart Vision Intelligent	L6-OPT-SMV	1603.0890.02
Sampling Analysis Module	L6-OPT-SPV	1603.1200.02
CE Compliance Test Software for Flicker	LT-CE-FLK	1603.1222.02
CE Compliance Test Software for Harmonics	LT-CE-HRM	1603.1239.02
CE Compliance Test Software for Standby Power	LT-CE-STBY	1603.1251.02
Choose your accessories		
Set of Interconnection Cables, 3m.	LMG-Z309P	1603.2858.02
Set of Interconnection Cables, 6m.	LMG-Z310P	1603.2887.02
Set of Interconnection Cables, 10m.	LMG-Z311P	1603.2912.02
Choose your Precision Current Transducers		
Precision Current Transducer 200 Arms	PCT200	1603.1880.02
Precision Current Transducer 600 Arms	PCT600	1603.1900.02
Precision Current Transducer 1200 Arms	PCT1200	1603.1874.02
Precision Current Transducer 2000 Arms	PCT2000	1603.1897.02
Choose your Precision Current Transducer Accessories		
Connecting Cable for PCTs	PCTX-K-L6	1603.1951.02
Plug N' Play Adapter PCT to LMG	L60-X-ADSE	1603.1100.02
Power Supply Unit for 4 PCT Sensors, 1U.	PCTSIU4-1U	1603.1922.02
D-SUB Interconnection for PCT, 2m.	PCT-DSUB2	1603.1845.02
D-SUB Interconnection for PCT, 5m.	PCT-DSUB5	1603.1868.02
D-SUB Interconnection for PCT, 10m.	PCT-DSUB10	1603.1839.02
Choose your extras		
Mounting kit for installation in 19" rack for LMG611/671	L671-X-01	1603.1145.02
Mounting kit for installation in 19" rack for LMG641	L641-X-01	1603.1122.02
2 x Front Panel Handles	L6X1-H2	1603.1151.02
4 x Front and Rear Panel Handles	L6X1-H4	1603.1168.02

Who We Are

ZES ZIMMER's focus lies on broadband single-/three-phase precision power analyzers. The electric and electronics industry uses them in R&D and for quality assurance; test labs employ them to guarantee compliance with standards; and universities rely on them to train future generations of engineers and scientists.

Thanks to their precision and reliability, the power analyzers of ZES ZIMMER's LMG series have conquered a leading position in the market. Our innovative measurement technology helps our customers not only keep up with developments in the power electronics industry but also provides them with an effective means to leapfrog ahead of their competitors and place their company and products in pole position. It is our commitment to enable our customers to get fast, precise and reliable results in order to solve their measurement tasks efficiently; our time-proven technology and our decade-long experience in power analysis provide all it takes.

Accredited calibration services

- Reliable and comparable calibration results
- Full metrological traceability for audits and quality assurance
- Highest quality standards through certified processes and expert staff
- Worldwide recognition through ILAC MRA as well as DAkkS accreditation
- We are ISO certified:



For further information, personal consultations, or details regarding calibration, service, and repair, please reach out to ZES ZIMMER or your local R&S sales representative.



© 2026 - ZES ZIMMER Electronic Systems GmbH - A Rohde & Schwarz Company- subject to technical changes, especially product improvements, at any time without prior notification.
Please refer to the enclosed data sheet for changes

ZES ZIMMER
A Rohde & Schwarz Company

Germany
ZES ZIMMER Electronic Systems GmbH - A Rohde & Schwarz Company
Pfeiffstraße 12 • D-61440 Oberursel
info@zes.com • +49 6171 88832-0
www.zes.com