

## Measurement of standby power and energy efficiency

### Abstract

While it is usually no problem to measure power higher than about 20 W with high accuracy, measuring low power may be difficult. This application note lists some of the possible pitfalls and outlines recommendations on how to avoid them.

Today it is common sense that it is a good idea to save energy. Reducing the standby power consumption of electrical devices is one potential candidate for doing so. Even though the power consumption is usually just a few watts for each device, the world wide number of billions of such devices results in a huge waste of power. Therefore for good reasons, efforts need to be undertaken to reduce the unnecessary power consumption not only in normal operational modes but as well for the standby mode.

Energy Star, EuP (Energy using Products, directive 2005/32/EC in conjunction with regulation 1275/2008) and others, as well as standards like EN 62301 define the marginal value of power consumption along with the measuring methods and circumstances under which compliance to those limits has to be verified.

### Wiring the measuring circuit

When measuring power consumption there are two possible measuring circuits. The first one (fig. 1) measures the correct voltage and an inaccurate current supplying the device under test plus the instrument. The other one measures a correct current, but a distorted voltage (fig. 2).

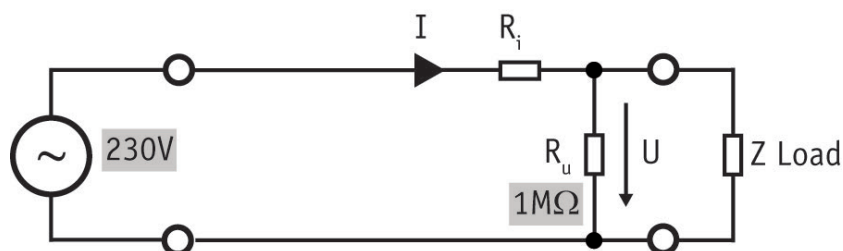
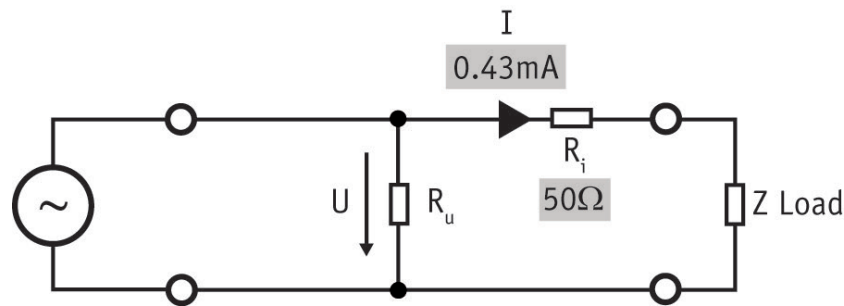

Fig. 1: Voltage correct measurement.  
Preferred, when current through  $R_u$  is very small compared to the current through  $Z$ . Power loss in  $R_u$ : 53 mW

For high currents, a circuit according to fig. 1 is used. Here the current through the load is usually by magnitudes higher than the current through the measuring device. Likewise if the voltage drop over the measuring device is small compared to the supplying voltage than a wiring as shown in fig. 2 is preferred.



**Fig. 2: Current correct measurement**  
 Preferred, when voltage drop over  $R_i$  is very small  
 compared to the voltage drop over  $Z$ . Power loss in  $R_i$ :  $9.2 \mu\text{W}$

Likewise if the voltage drop over the measuring device is small compared to the supplying voltage than a wiring as shown in fig. 2 is preferred. Typical power measuring instruments have a  $R_u$  in the voltage channel of  $1 \text{ M}\Omega$  and more, so the power loss is in the range of  $0.05 \text{ W}$ . The dissipation loss of the current channel, however, can rise to several watts with normal appliances operating with the mains voltage (e.g.  $R_i = 10 \text{ m}\Omega$ , with  $10 \text{ A}$  yields  $1 \text{ W}$  loss power). For standby power consumption measurements the reader is strongly advised to use the wiring in fig. 2.

If a standby power consumption of  $100 \text{ mW}$  is assumed, a wiring according to fig. 1 will result an error of  $53 \text{ mW}$ . For the circuit wiring according to fig. 2 the power consumption in the current channel would only be  $9,2 \mu\text{W}$ .

The result is a relative error of  $53 \%$  in the case of fig. 1, but only  $0.01 \%$  in the case of fig. 2! Since this kind of error is systematic, so why not taking it into account? The exact values of  $R_i$  and  $R_u$  are unfortunately in reality not very well known since they are e.g. frequency dependent. The error caused by the wiring is thus usually ignored. Fortunately, with a correct chosen wiring as shown above this error can in the majority of cases rightfully be neglected because it is then much smaller than the measuring errors of the instrument.

## Range

In order to measure such small currents as in the example above, it is usually not sufficient to use the built in range of an instrument. A measurement device with a range of  $5 \text{ mA}$  would be using only  $10 \%$  or less of its range, causing a large measuring uncertainty.

Another problem is the potential overload of such small ranges. For example when a refrigerator starts its compressor, while the instrument is in the  $5 \text{ mA}$  range, a current of  $10 \text{ A}$  can flow for several seconds. This could possibly destroy the instrument. To avoid this problem ZES ZIMMER has developed special external shunts. The shunt series SHxxx-P consists of several shunts which have rated current ranges from  $500 \text{ mA}$  down to  $150 \mu\text{A}$ . Additionally is the internal protection which allows the device to be used with currents of up to  $20 \text{ A}$  continuously.

## Range selection

Should the measurement use automatic range selection or manual range selection? Both have advantages and disadvantages, depending on what to measure. For a better understanding the following paragraph explains how automatic range selection works in principle:

During a measuring cycle, the instantaneous value of the current might exceed the maximum value of the ADC (Analogue to Digital Converter). The instrument detects this situation and stops the running measuring cycle. Already sampled values are discarded. Now the instrument switches to the next higher range of the measuring channel. Implicitly with that comes a gain change of the internal amplifiers and filters which requires a signal settling time. All values recorded during this period which takes about 50 ms must be discarded. After that the instrument has to synchronise itself to the signal before a new cycle is started. At the end of this cycle new valid values are available.

If the instrument has to switch up several ranges, this algorithm is performed several times consecutively.

### **In brief: Switching a range causes a measuring gap.**

This is critical for pulsed currents.

## One Example

Let's envisage a low nominal current having a peak 1000 times higher for about 20 ms every 2 s. While running automatic range selection, this peak will always be discarded, because at the beginning of the peak, the range will be shifted as described above. Automatic range switching is thus convenient but in some cases not useful at all. For highly dynamic measuring situations the manual range selection is preferred.

The situation is slightly different if the signal becomes too low for a range. Imagine a relatively long measuring cycle. Almost immediately after the start of a new running cycle the consuming device switches from normal mode down to standby. This would justify a lower range. However, at the end of this measuring cycle, the instrument has correctly registered, that the peak value of the measured signal was still within the actual range. Only after the end of the following cycle the instrument can detect, that it should switch down to a lower range using the algorithm already described above.

In brief it can be summarized here that shifting the range down will result in a signal measurement with low accuracy and a loss of samples for about 2 cycles. If your device has a constant input current it doesn't matter how to select a range. But in a worst case it could happen with automatic range selection, that a pulsed signal is measured completely wrong: The pulses occur in the gap when switching up, and the signal between them is measured in a range which is too high. Thus, whenever it is possible it is recommended to use manual range settings. In many cases the higher error caused by a range which is too high for some signal parts is not as fatal as missing

signal parts like peaks. Please remember, that rms values are measured according a square law:

$$I_{TRMS} = \sqrt{\frac{1}{T} \int_{-0}^T i(t)^2 dt}$$

This shows that a signal part with let's say a 100 times higher amplitude will influence the result by a factor of 10000!

## Where to measure the current

For single phase applications it is usually recommended to measure the current in the neutral wire. By doing so the current channel of the instrument is not floating and hence not a subject for common mode signals. This could particularly be a problem for cheap instruments because their common mode rejection of only 60 dB-80 dB might not be sufficient!

However such a recommendation may lead to wrong measurement results. Fig. 3 shows a simplified circuit. To fulfil the EMC requirements the circuit has a filter with capacitors ( $C_x$  and  $C_y$ ) and so the device is actually not a 2 wire but a 3 wire system because of  $P_E$ . Only by measuring  $I_L$  the entire current flowing through the device is measured. And obviously due to the fact that loads in reality usually contain reactive and non-linear components it should be clear that only measuring the current and multiplying it with the nominal voltage in order to calculate the power consumption cannot suffice.

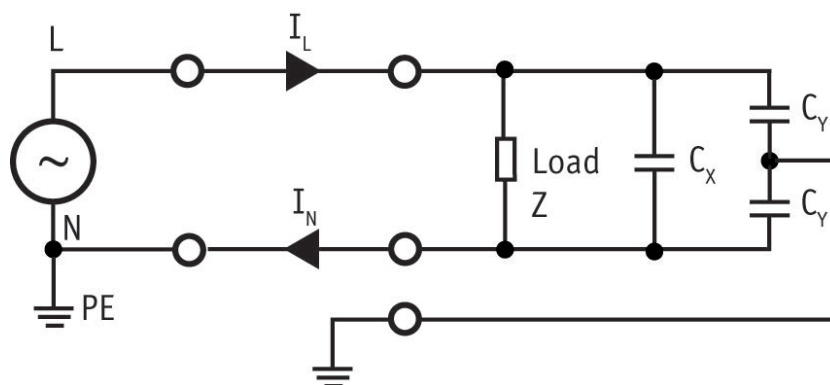

**Abb. 3: Where to measure?**  
 With one power meter the current  $I_L$  must be measured, because the load has a 3 wire connection.

## Gapless Measurements

As written in section “Range selection”, a gap in the measuring algorithm can end up in completely useless results, especially under conditions where the input current is not constant. This gap occurs with every instrument for the reasons explained above.

But there are also other causes for gaps which can be avoided: Some cheap instruments have to work in two modes due to its limited processing capacity. At first they measure for several periods. Then the data is processed and displayed. Data acquisition is halted during the latter phase. This kind of measuring is similar to the operational modes of digital oscilloscopes and sometimes advertised as “non gapping average values”: Only the measuring over several periods is non-gapping (these are used for the average value), but there are gaps between the average values!

Another reason for measuring gaps might be the compensation of DC errors in the measuring channel: Each operational amplifier has by nature a DC offset which seems to be part of the measuring signal. This DC offset has to be compensated inside the instrument by one of the following methods:

During artificially generated measuring gaps, the channel is disconnected internally from the measuring signal, so the DC produced by the channel itself is determined and can be compensated internally for the upcoming cycles, until the whole process has to be repeated.

The other approach is to compensate the DC offset permanently by adjusting the instrument. The latter method requires high quality components with a small drift, so that the offset adjustment is valid at least for the same period as the calibration. Therefore this approach is only used for high end instruments.

The above can be summarized as: Simply designed instruments have to generate gaps to compensate the effects of their low cost components. The ZES ZIMMER power meters of series LMG95, LMG450 and LMG500 never let any of these gaps occur, because they use:

- high speed DSPs which process the sampled values in real time.
- high end precision operational amplifiers which require an adjustment of the DC only once a year.

## Additional settings

Also with the methods described above to reduce the DC errors of the channel itself, some small errors still remain. Mentionable is that the DC components of voltage and current will result in active power. Usually this power dissipation is negligible but when measuring small values such as standby power consumption, these small values might inflict a higher percentage measuring error. It is therefore recommended to use an AC coupling mode, so that such errors are eliminated. This will increase the accuracy significantly.

## Bandwidth

The required bandwidth of the measurement is dependent on the task. Several points should be taken into consideration: First, one has to remember that active power can only be produced by voltage and current components with same frequency. So if an ideal 50 Hz voltage source is available and only the active power which the DUT consumes from the source has to be measured, a bandwidth from 45...55 Hz or 55...65 Hz would be entirely sufficient.

But in a real world the mains has harmonics in the voltage. They will generate active power and harmonics in the current. With a measuring bandwidth of about 2 kHz this effect is sufficiently covered. Additionally there are two more impacts: Some devices use input circuits which are switched with frequencies starting at 2 kHz and go up to more than 50 kHz. Their currents could cause voltage drops over the resistive and (more important) inductive part of the internal wires.

Those are the sources for additional voltage/current tuples which consume active power for each frequency. On the other hand the power source – especially if it is a switching power supply – might have a remaining ripple on the voltage. A value of 1 V and frequencies in the range of 40 kHz are common. This voltage can drive appreciable currents, especially through filter capacitors ( $C_x$ ,  $C_y$ , see fig. 3) but also in a conventional switched power supply, when the diodes of the rectifier are in conductive mode. In such cases further active power might be consumed.

For energy saving intentions, a bandwidth of 2 kHz should be sufficient. Estimates about the thermal effects need to take the active power above 2 kHz being generated and physically consumed into account. Otherwise the calculation might be completely wrong. In any case a rich selection of filters is good to have for determining easily in which frequency band the power is being consumed. Alternatively, the harmonic analysis function - if the power meter has one - can also calculate the active power produced at each frequency.

## Accuracy

When taking a look at EN 62301, Annex B.5 you'll find the following sentence:

**“Generally, a digital power analyser with a fundamental power accuracy of 0.5 % or better will comfortably meet the instrument specification and measurement uncertainty required in this standard.”**

At first glance is this great. For 0.5 % fundamental power accuracy you will find a lot of cheap instruments. But, the above is an informative annex and the real requirements are specified in chapter 4.5:

**“Measurements of power of 0.5 W or greater shall be made with an uncertainty of less than or equal to 2 % at the 95 % confidence level. Measurements of power of less than 0.5 W shall be made with an uncertainty of less than or equal to 0.01 W at the 95 % confidence level.”**

Seemingly the two phrases do not contradict to each other but the devil is in the details. Here at

ZES ZIMMER we manufacture probably the most precise single phase power meter on the market, the LMG95. So let's do the error calculation for this device:

The standard accuracy at 50 Hz for a power measurement is specified as:

$$\pm (0.015 \% \text{ of reading} + 0.01 \% \text{ of range})$$

Along with the error of the shunt SHxxx-P we get a maximum total uncertainty of:

$$\Delta P = \pm (0.165 \% \text{ of reading} + 0.01 \% \text{ of range})$$

which is about 1/3 of the recommendation of the standard.

## Example 1a

A 10 W load, power factor is 1.0 (i.e. a fully ohmic load). The current is 43.48 mA, used is the range with 50 mA nominal value and a peak value of 156.3 mA

$$\Delta P = \pm 0,023 W$$

This is a relative error of 0.23 %, which is less than the standard's requirement of 2 %.

## Example 1b

A 10 W load, the power factor is 0.3 and the crest factor is 3, typically for a switching power supply in this power range. The current is 144.9 mA with about 435 mA peak value. We have to use a range with 250 mA nominal value and a peak value of 781.5 mA

$$\Delta P = \pm 0,048 W$$

This is a relative error of 0.48 %, which is lower than the standard's requirement of 2%.

These two examples do not look like a challenge, at least not for such a precise instrument. For an instrument with a lower specification of 0.5 % fundamental power accuracy this would also not be a problem. But this was at a fairly high power. Let's therefore repeat the calculation with a typical standby power of 0.5 W:

## Example 2

A 0.5 W load with a power factor of 0.1 and a crest factor of 6 which is typical for a switch mode power supply in this power range. The current then is 21.74 mA with a 130.43 mA peak value. The chosen range is 50 mA nominal value and a peak value of 156.3 mA

$$\Delta P = \pm 7,077 mW$$

This is a relative error of 1.42%, which is lower than the standards requirement of 2 % and the absolute error is less than 10 mW.

As it can be seen the required tolerance of 2 % resp. 10 mW is already utilised by 70 %.

Clearly does a much lower specified instrument according annex B.5 not “comfortably meet” the requirements of the standard. But please bear keep in mind that EN 62301 does not limit the uncertainty of the instrument but the uncertainty of the complete measurement setup.

## **No instrument will fulfil the standard under all circumstances!**

In the above examples values were used which are today the edge of the technology: A power factor of 0.1 and a crest factor of 6. Sophisticated „0 W PCs“ already have crest factors of 14. It is hard to imagine what else will be developed in the future or already exists, but it is certain that an EUT with a power factor of 0.01 and a crest factor of 100 cannot be measured with any existing instrument within the required uncertainty of 2 %.

So it is not reputable if a manufacturer advertises that the instruments meet the requirements or are certified concerning EN 62301. A general statement like this is untrustworthy for the reasons explained above.

### **Examples:**

Manufacturer Y attained under almost ideal conditions (range fully used, crest factor < 3, ...) already a usage of 70 % of the allowed uncertainty only by regarding the instrument without the environment Such an instrument can hardly be used in practice, because such conditions cannot be found in reality. It seems wry that this instrument is advertised as certified for measuring standby power.

Likewise also manufacturer V achieves the requirements of the EN 62301 according to his own calculation under almost ideal conditions (power factor 1, ideal external shunt ...). 85 % of the allowed uncertainty is used by the instrument itself, again without any external components which are essential. Likewise, this instrument as well can hardly be used in practice. Nevertheless the manufacturer guarantees to measure according to the requirements of EN 62301 if some technical hints and the terms expressed in the manual are met.

Such delusive certificates and guarantees, valid only under ideal conditions, will last until the first uncertainty calculation with a real world EUT takes place. If the daily grind shows that these instruments will not be able to keep their certificates or guarantees promises, the bill will be paid by the customer, not by the manufacturer.

### **Frankly spoken: Our products cannot measure everything under all circumstances!**

On the other hand we at ZES ZIMMER won't hide behind fancy guarantees and certificates. Serious certificates and guarantees have to show the limits of an instrument clearly, because global statements are not possible as shown above.

This leads to the fact that users can't trust to the certification of an instrument only but has to make themself familiar with the contained limits. So we will use the two foregoing examples to calculate our uncertainties to be comparable:



For the “Y” example (230 V, 20 mA, CF<3, 0.46 W) we use a range with nominal value of 24 mA and peak value of 78.12 mA. Our product achieves an uncertainty of 0.84 % which is the usage of only 42 % of the requirements of the standard. So our instrument is roughly 2 times better than the competitor and the requirements.

And for the “V” example (230 V, 4.3 mA, CF<3, 1 W) we apply a range with nominal value 5 mA and peak value 15.63 mA. An uncertainty of 0.23 % is the worst case, which is the utilization of 12 % of the allowed 2 % uncertainty - roughly 7 times better than the competitor and the requirements. Certificates aren't necessary at all.

Can I test if a measuring instrument is suitable for this kind of measurement?

## Yes and no!

**Yes**, you can measure if an instrument has a sufficient accuracy at the time of calibration. But this is not really relevant, because even an instrument with 10 % specified uncertainty might have an error at calibration time of 0 % by coincidence!

**No**, calibration is a singular event. Every manufacturer tries to specify its instruments as accurate as possible. Additionally, they are designed to meet the specification for a certain period at minimum, typically 12 months. During that time a lot happens. Drift, ageing, chemical reactions... they all influence the accuracy over time and cannot be contained in an one-time calibration. But the manufacturer's specification takes care for it. So if the above 10 % instrument has 0 % error according to the calibration protocol, it is quite likely that this instrument will have much more than 2 % after one year. Had it been designed for a better specification, the documentation would tell it!

So it is as much important to look for a good specification as to have a valid calibration protocol. A calibration with a good result is never a replacement for a bad specification.

## How to build up a reasonable testing system?

The provocative message of last chapter that no instrument will completely fulfil the standard is unfortunately true. Nevertheless there are some strategies to perform these kinds of tests seriously:

- Use an instrument with smallest possible uncertainty. A 0.025 % instrument can be used for way more critical EUTs than a 0.2 % instrument!
- Calculate the (instrument) uncertainty for each measure point. This is the only way to get an impression about the reliability of the results and to exploit the limits of the instrument.

If one complies with these two rules, one will always receive a reliable testimony about the measurement. This might be important in cases where regulatory authorities question the results. Vertreten muss und bei Verletzung von Grenzwerten empfindliche Strafen drohen können.

## **Additional influencing factors**

The EC directives as well as EN 62301 require an uncertainty of 2 % at 95 % confidence level. Not only the instrument uncertainty but all other influencing factors are included in this marginal value. This requirement is extremely important to get a good reproducibility! Remember that all of the own measuring results should be reproducible by any regulatory authority to prevent concerns. In this context it should also be taken into consideration that the product's parameters will have a spread in production.

Beside the usual influence factors like temperature, air flow, humidity, etc. the following points should be regarded: The voltage and current harmonics, as described under "bandwidth" can have significant influence. A simple measuring at the mains has shown that especially the harmonics of the 3rd, 5th and 7th order make up 2 % of the total active power consumption of the EUT. The total harmonic distortion (THD) was 3 % (EN 62301 allows only 2 %) but also with much smaller THD, errors in this range are possible. The error depends very much on the value of each voltage harmonics and on the phase shift to the corresponding current harmonic, so the 2 % can also be exceeded. In other words: The voltage source itself can generate 2 % uncertainty of the final result on its own.

For this reason you should use a voltage source with a very small THD to minimize this error. Further more you can determine the distribution of the power dissipation on the harmonics by using a measuring mode which measures active power for each harmonic. Thus, you'll get knowledge instead of an estimate.

Also the voltage amplitude itself can influence the power reading, depending on the functional principle of the device: The power value of +1 % deviation of the nominal voltage might be much bigger than the value at -1 % deviation, that the allowed 2 % uncertainty is already exceeded.

## **Conclusion**

We have briefly outlined that the measurement of standby power and energy efficiency is not trivial, neither for the operator nor for the required equipment. Several errors may occur while measuring standby power and other kinds of energy efficiency. Some can be avoided by applying rarely needed and sometimes forgotten but nevertheless fundamental knowledge.

We hope to have made a clear point that an inside knowledge on how measuring instruments work helps in getting correct and reliable results. This application note should have provided the necessary information.

With a carefully chosen and adequate instrument, these measurements can be run successfully. We have used the following instruments for our examples

- LMG95 with LMG-SHxxx-P or
- LMG95 with modified current inputs or
- LMG500 with LMG-SHxxx-P

Further options and equipment, like a power source (e.g. ZES ZIMMER 801RP, single phase/0.8 kVA) may be necessary to meet the requirements in other applications.

## Author

Dipl.-Ing. Thomas Jäckle  
Development and Applikation  
ZES ZIMMER Electronic Systems GmbH